

INSTALLATION & SERVICE MANUAL

SM-0010
Rev. B

HDXL6 MODEL DOOR
DIMENSIONS IN PARENTHESIS ARE IN MILLIMETERS

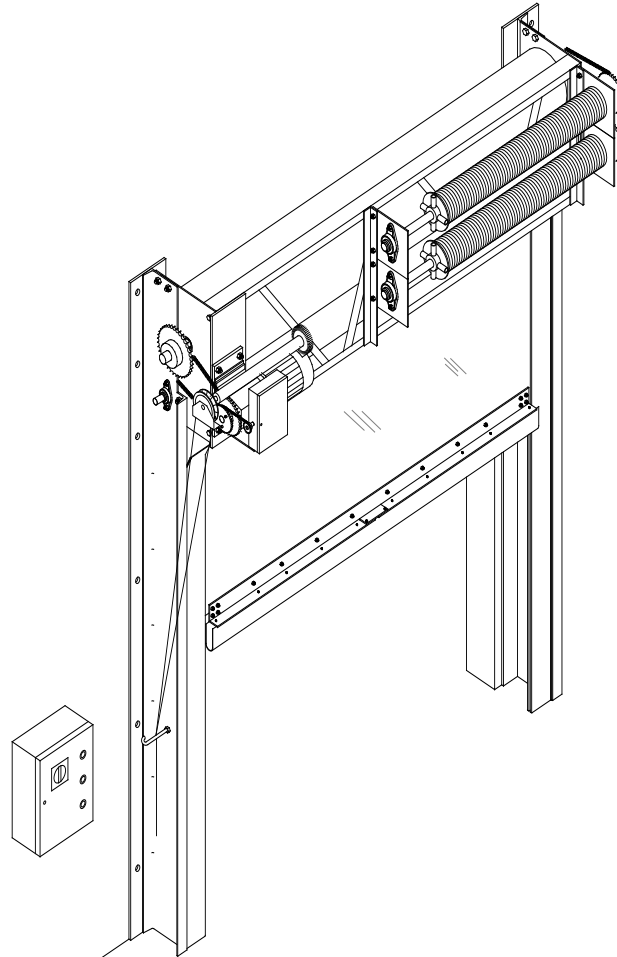

END USER:

DEALER:

DOOR SERIAL #: TNR-

DOOR MODEL: HDXL6

DOOR SIZE: WIDE X HIGH

DOOR HANDING:

INSIDE TO INSIDE MEASUREMENT: OPENING WIDTH + 12" (305)

HÖRMANN

TOLL FREE: 1-866-792-9968

TEL: 1-705-792-9968

WEBSITE: hormann.us

MANUAL-002

Limited Lifetime Warranty

HD SERIES Rubber Doors



Models HDM, HDD, HDP, HDLH, HDXL6, HDXL9, HDL23, HDL23-DD, HDL45, HDL45-DD, HDC, HDC-DD

All door systems manufactured by TNR Industrial Doors Inc. (hereinafter, TNR) are warranted from the date of shipment against defects in materials and workmanship, according to the following:

Curtains and Curtain Loks: The NEWGEN® Guide and Curtain Lok™ system and curtain material are warranted against defects in material and workmanship for the lifetime of the door. Undesirable aesthetics of the curtain not causing performance issues of the door are not considered a defect and are therefore not covered under this warranty.

Undesirable aesthetics of windows not causing performance issues of the door are not considered a defect. Normal window wear and aging are not covered under this warranty.

Operators with variable frequency drive: Warranted for five (5) years or 1,000,000 cycles, whichever occurs first.

Operators without variable frequency drive: Guaranteed against defects in materials and workmanship for a period of two (2) years.

Mechanical: All other mechanical components are warranted against defects for two (2) years with unlimited cycles.

Electrical: All electrical components including sensors are warranted against defects for two (2) years or 300,000 cycles, whichever occurs first.

Counterbalance springs have a defined life as determined by the cycles of a door. If a counterbalance spring fails prior to its designed cycle life and within the first two (2) years from date of shipment, it will not be considered defective but will be covered on a pro-rated basis under this warranty.

Brake pads, bottom bar arms and inertia brakes are wear items and are not warranted against normal wear, however, they are warranted for two (2) years against defects in materials and workmanship.

Replacement Parts: All replacement parts supplied under warranty remain covered until the end of the original warranty agreement or component specific period noted below, whichever occurs last.

- Curtains, two (2) years
- Operators, one hundred and eighty (180) days
- Control Boxes, one hundred and eighty (180) days
- All other mechanical and electrical components, ninety (90) days

Items that may void the warranty include but are not limited to powering doors with a generator, lubricating guides or curtain, drilling holes in the limit box or control box or other enclosure in any location other than the bottom of the enclosure, not ordering control box or operator heaters where the control box or operator will be installed in temperatures below 41°F (5°C), not installing buck boost transformers on Feig control boxes where the primary supply voltage is measured at less than 210VAC, not using the appropriate electrical conduit/fittings for the environment, improper installation, inadequate building framing and clearances, environmental conditions that TNR was

Limited Lifetime Warranty

HD SERIES Rubber Doors

Models HDM, HDD, HDP, HDLH, HDXL6, HDXL9, HDL23, HDL23-DD, HDL45, HDL45-DD, HDC, HDC-DD



not made aware of in writing prior to the door being ordered, modification to the door system without prior authorization from TNR.

Documented proof of completion of the recommended Maintenance Schedule in the *Owner's Manual for Operation and Maintenance* must be provided with warranty claims – warranty is void without proper documentation.

If, within the applicable warranty period stated above, any parts are found to be defective, replacement parts will be supplied free of charge, F.O.B. TNR's plant in Barrie, Ontario, Canada. Warranty only applies provided that recommended installation and maintenance procedures have been followed, as outlined in the *Owner's Manual for Operation and Maintenance*.

This warranty does not include replacement of parts due to damage beyond the control of TNR, such as damage in transit, impacts, caustic environments, or damage during storage. If door is not installed when it arrives on site, TNR strongly recommends the door is protected from weather and damage. The door should be covered and secured in a dry, enclosed building until it is installed.

Warranty claims must be made to TNR or to the authorized distributor where the door was purchased. Defective parts are to be returned to TNR in Barrie, Ontario, Canada, prepaid, for verification of the warranty claim. Any warranty coverage is only effective after the door is paid in full.

Additionally, at the time of delivery, it is important to verify that all parts (pieces should match with the bill of lading/packing slip) have been received and that no damage has occurred during shipping. If any missing parts or damaged components are identified, note any damages and/or shortages on the bill of lading/packing slip, then sign it. In the event that this happens, please send TNR a signed copy immediately.

Introduction

The information contained within this manual will allow you to install your TNR Industrial Door to maximize its life and give you years of trouble free operation.

Failure to follow the procedures contained within this manual may result in injury or death, damage to property or the product. Any deviations to the procedures or alterations to the product that are not authorized by TNR Industrial Doors will automatically void the warranty and may cause injury or even death.

Always refer to the electrical schematic/wiring diagram that ships with the product when making all electrical connections as this electrical schematic/wiring diagram is built specific for that product. Verify the serial number of the product on the schematic/wiring diagram.

DO NOT INSTALL OR OPERATE THIS PRODUCT UNTIL YOU HAVE READ AND UNDERSTAND THE CONTENTS OF THIS MANUAL AND THE ELECTRICAL SCHEMATIC/WIRING DIAGRAM.

If you have any questions about this manual or how to install, maintain, or use the product, contact TNR Industrial Doors at 1-866-792-9968. Refer to the serial number when contacting TNR Industrial Doors. The serial number can be found on the electric operator, control panel, and drive side mounting angle.

The following symbols represent varying degrees of attention that need to be paid to the instructions that accompany them.



WARNING – This symbols indicates potential for personal injury or even death, if the procedure is not performed as described.



CAUTION – This symbol indicates potential for damage to the product or property, if the procedure is not performed as described.



IMPORTANT – This symbols indicates information that is critical to the successful completion of the procedure.



NOTE – This symbol indicates information to aid in the proper operation of the product or completion of the procedure.



Always ensure that when installing multiple doors that all of the parts correspond to the correct serial number for that door.

Verify the contents of the shipment with the packing slip to ensure that there are no missing parts. If there is anything missing contact TNR Industrial Doors immediately to allow prompt delivery of the missing parts and minimize any delays in the installation of the product.

Installation

Required tools, materials, and equipment

- Fasteners to attach the door to the structure. Fastener type and size will depend on the structure construction and door size.
- Welder if not using fasteners to attach the door to the structure.
- Hammer drill if attaching the door to masonry.
- Masonry and steel drill bits.
- Assorted shims.
- Tape measure or laser distance finder with minimum measuring distance of opening width plus 18".
- Laser level, transit level, water hose level, or line level and string.
- Minimum 4 foot spirit level.
- Assorted metric and standard hand tools – screw drivers, pliers, wrenches, socket set, pry bars, hammer/mallet, allen keys, etc...
- Power tools – Drill, grinder, impact gun
- 2 pieces of round bar for winding counterbalance springs – 5/8" diameter and minimum 24" long
- Two ladders that can safely reach a minimum height of the opening height plus 24".
- Forklift or crane and lifting straps



The capacity of the crane or forklift must be sufficient to hoist the header assembly into place. Minimum height capacity for crane or forklift is dependent on the door model. Contact TNR Industrial Doors for door specific size and weight.



The mounting surface must be free of obstructions. If the mounting surface is uneven use shims as necessary to ensure the door mounting angle/tube is installed plum and in contact to the mounting surface.

Labour

Two qualified installers. – Technician training is available from TNR Industrial Doors.

Qualified welder – See installing the mounting angles/channels/tubes for welder qualifications

Qualified electrician



Limit access to the work site to authorized personnel only.

Electrical requirements

Ensure that all electrical power sources have been locked out and tagged out according to OSHA regulations and local electrical codes. Test the equipment to ensure it can't start moving and that the electrical power is disconnected prior to commencing work.

All electrical work must meet local, provincial/state, and federal codes.

Ensure that any local disconnects, fuses, or breakers are sized correctly for the product.



Personal protective equipment

- Hard hat
- Safety glasses
- Welding helmet and gloves
- Grinding face shield
- Work gloves
- Safety boots
- Fall arrest gear

Automated door set up recommendations

Dimensions in parenthesis are in millimeters

SM-0419
Rev. A

It is the responsibility of the company that sold the door to the enduser to ensure that the door is set up in such a way to provide adequate protection from accidental impacts/collisions with the door. Below are TNR Doors minimum recommendations when setting up a door to be used by sensors and timers to automatically open, close, and reverse the door when an obstruction is present.

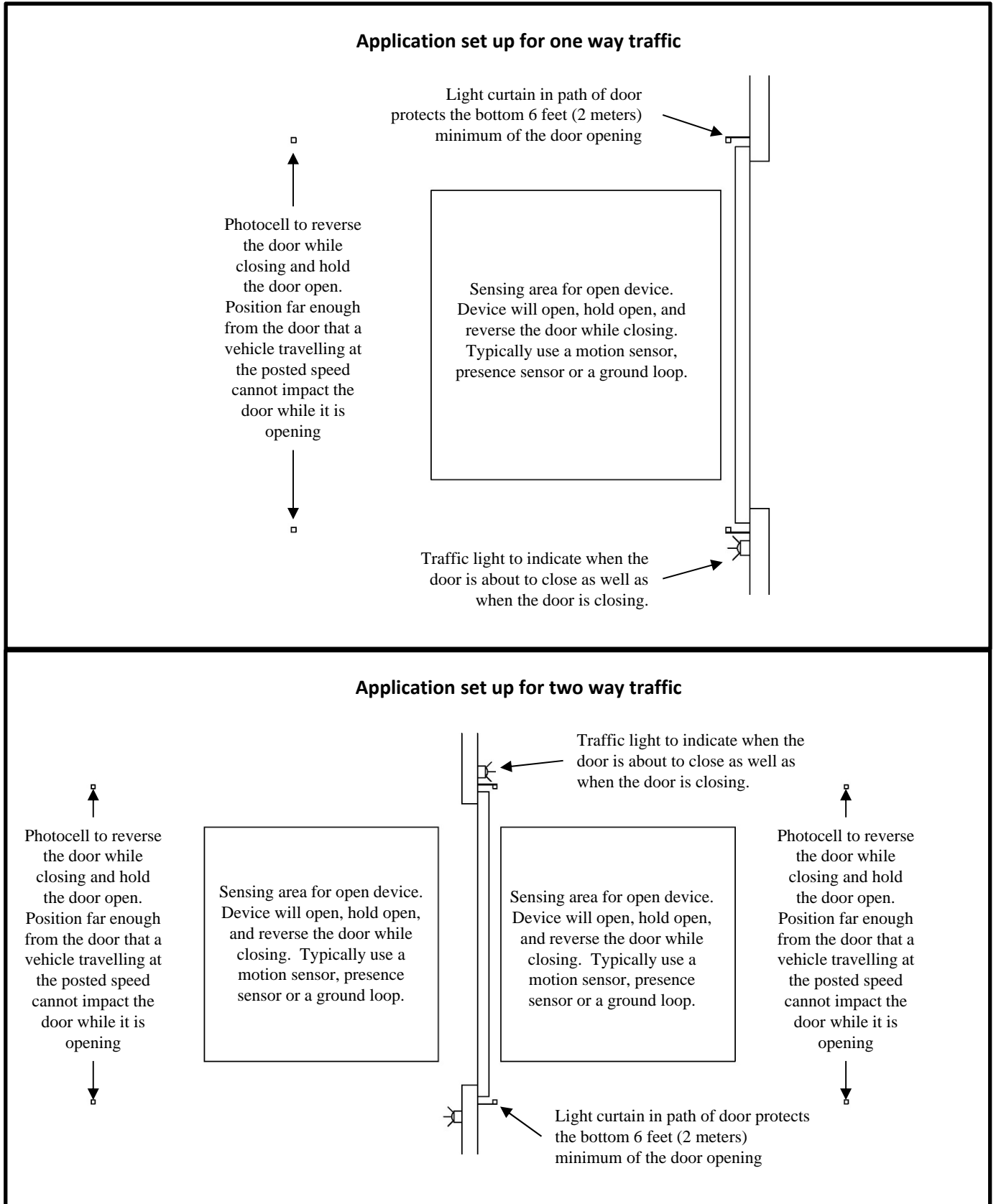

Safety Label Information and Instructions

- There are two door safety labels which have been provided to warn pedestrian traffic of the dangers regarding this high-speed door.
- It is recommended that these stickers are placed in a visible location by the installer, to warn pedestrians about the safe use of these doors.
- Instructions of safe practices around the door can be seen on the lower half of this sticker



INSERT SHOP DRAWING HERE

VERIFY OPENING AND CLEARANCES
DIMENSIONS IN PARENTHESIS ARE IN MILLIMETERS

SM-0013

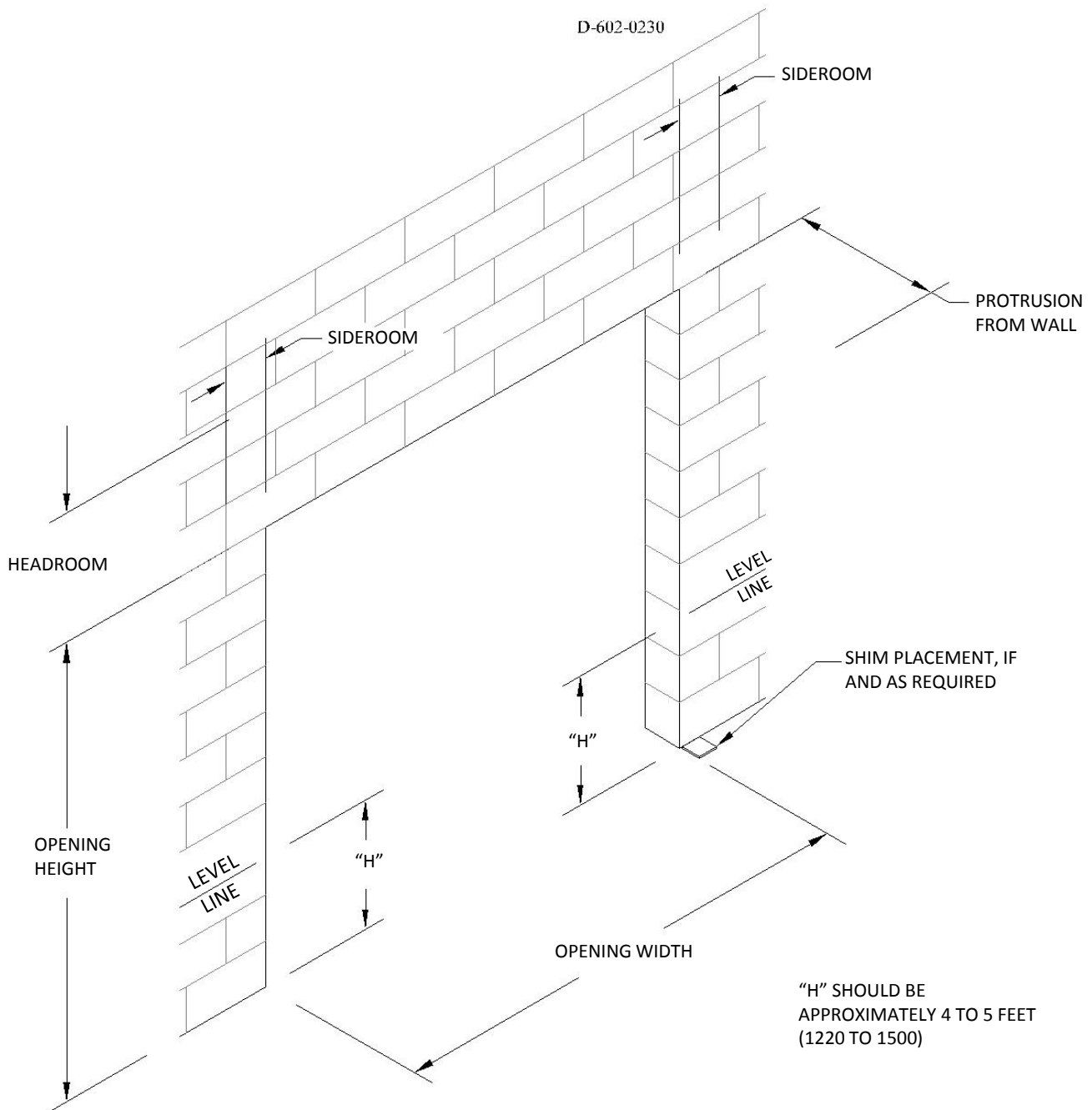

- (i) USE THE SHOP DRAWING TO VERIFY THE OPENING SIZE AND ASSURE ALL CLEARANCES ARE ADEQUATE PRIOR TO STARTING WITH THE INSTALLATION OF THE DOOR.
- (ii) USING A WATER HOSE OR TRANSIT, MARK A LEVEL LINE ON EACH DOOR JAMB APPROXIMATELY 4 TO 5 FEET (1220 to 1500) ABOVE THE FLOOR.
- (iii) MEASURE THE DISTANCE FROM THE FLOOR TO THE LEVEL LINE ON EACH JAMB. IF REQUIRED, PLACE AN ADEQUATE SHIM, MINIMUM 4" x 4" (100 x 100), ON THE FLOOR BY ONE JAMB TO ACQUIRE THE SAME VERTICAL DIMENSION TO BOTH LINES.

MOUNTING ANGLE INSTALLATION VERIFICATION

SM-0121

DIMENSIONS IN PARENTHESIS ARE IN MILLIMETERS

LEFT HAND DOOR SHOWN

MOUNTING CHANNELS SHOWN IN STEEL JAMB CONFIGURATION

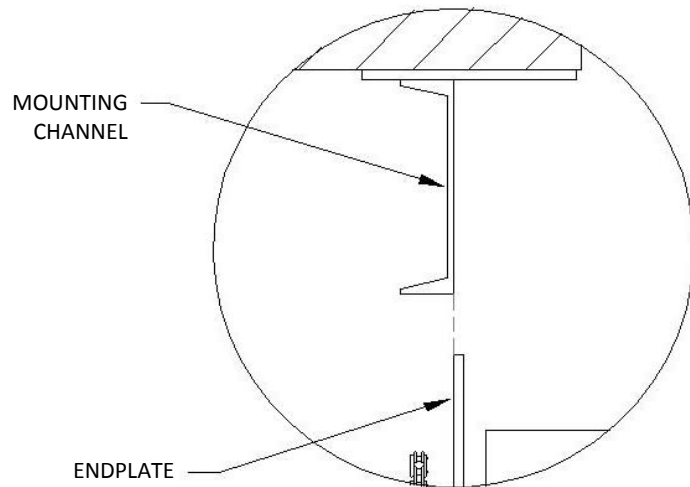
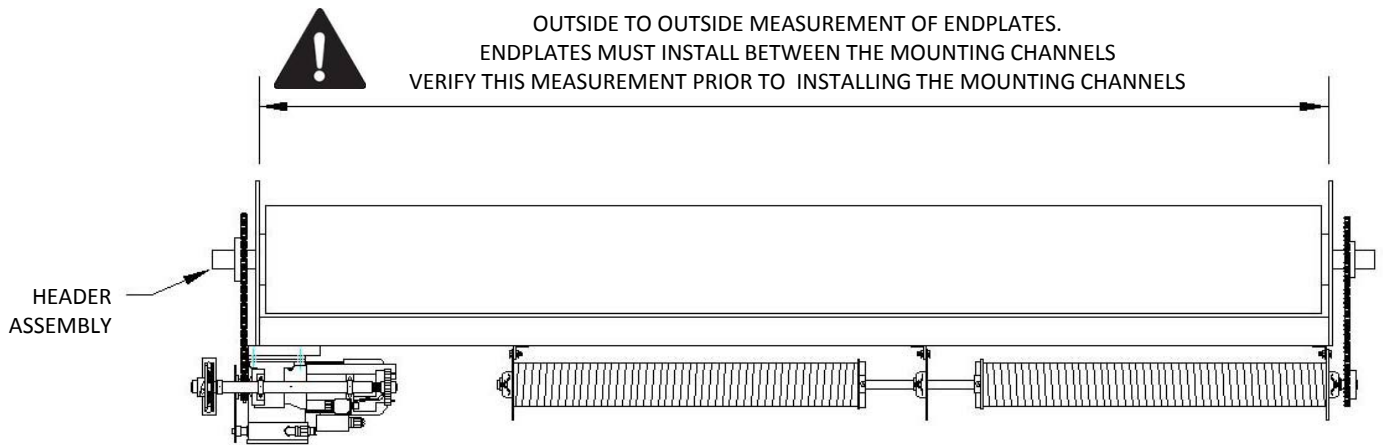
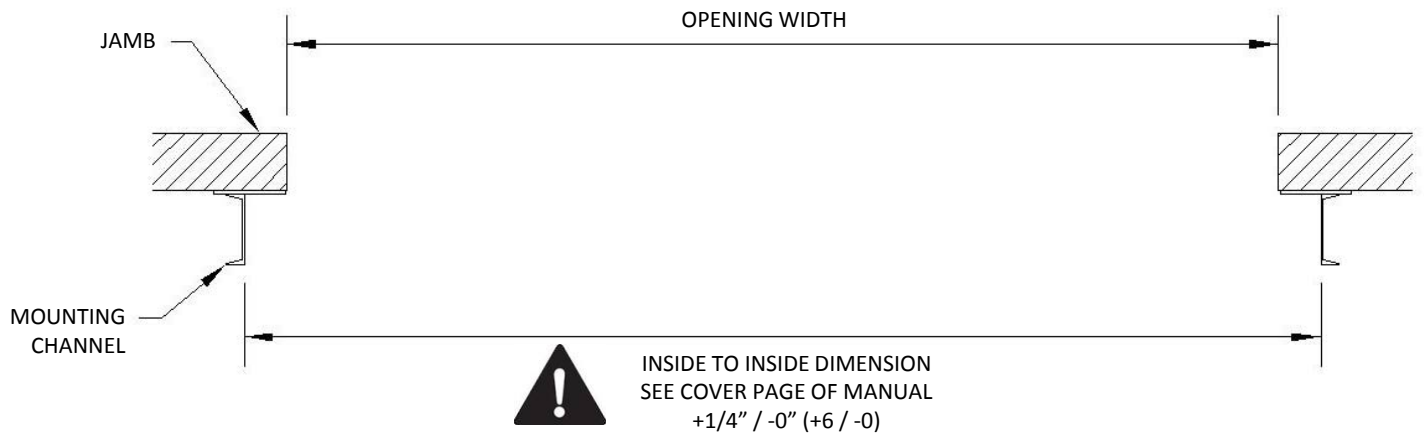

D-602-0318

**INSTALL DOOR MOUNTING CHANNEL
STEEL FRAMED BUILDINGS ONLY
DIMENSIONS IN PARENTHESIS ARE IN MILLIMETERS**

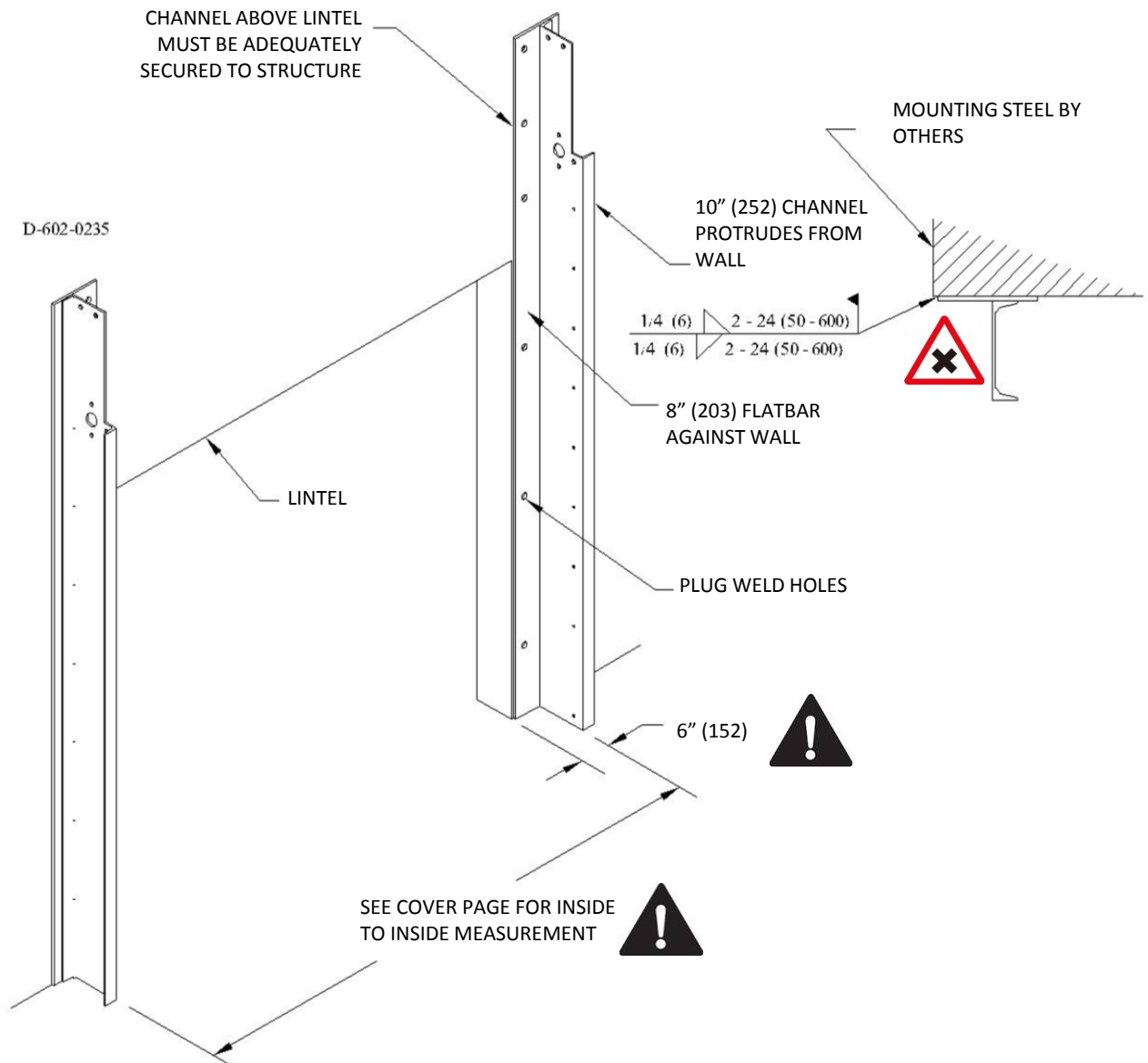

(i) FOR STEEL FRAMED BUILDINGS, STAND THE DOOR MOUNTING CHANNEL AGAINST THE WALL WITH THE 10" (252) CHANNEL PROTRUDING OUTWARD AND THE CHANNEL LEG EXTENDING AWAY FROM THE OPENING.

(ii) WITH THE INSIDE CHANNEL FACE SPACED 6" (152) FROM THE JAMB, WELD THE FLATBAR TO THE JAMB STEEL AS INDICATED ABOVE. THE DOOR MOUNTING CHANNEL MUST BE INSTALLED PLUMB WITHIN 1/4" (6).

(iii) INSTALL THE SECOND DOOR MOUNTING CHANNEL USING A HORIZONTAL MEASUREMENT BETWEEN THE INSIDE SURFACES OF THE TWO CHANNEL FACES. THIS MEASUREMENT IS ON THE COVER PAGE OF THIS MANUAL. CONFIRM THIS MEASUREMENT ON 48" (1220) VERTICAL INCREMENTS UP THE LENGTH OF THE CHANNEL. WELD THE FLATBAR TO THE JAMB STEEL AS INDICATED ABOVE.

(iv) PLUG WELD THE FLATBAR TO THE MOUNTING STEEL WHERE HOLES ARE PROVIDED. THE DOOR MOUNTING CHANNEL MUST BE SUPPORTED ABOVE THE LINTEL. IF MOUNTING STRUCTURE DOES NOT EXIST ABOVE THE LINTEL, INSTALL ADEQUATE BRACING.

! FABRICATORS AND ERECTORS RESPONSIBLE FOR WELDING STRUCTURES FABRICATED OR ERECTED UNDER CSA-S16 (THE DESIGN STANDARD FOR STRUCTURAL STEEL IN CANADA) SHALL BE CERTIFIED BY THE CANADIAN WELDING BUREAU TO THE REQUIREMENTS OF CSA STANDARD W47.1 (DIVISION 1 OR DIVISION 2) OR W55.3, OR BOTH, AS APPLICABLE. PART OF THE WORK MAY BE SUBLET TO A DIVISION 3 FABRICATOR OR ERECTOR; HOWEVER, A DIVISION 1 OR DIVISION 2 FABRICATOR OR ERECTOR SHALL RETAIN RESPONSIBILITY FOR THE SUBLET WORK. THESE STANDARDS ARE VALID IN CANADA ONLY THUS THE LOCAL EQUIVALENTS MUST BE APPLIED OUTSIDE OF CANADA. (THE U.S.A EQUIVALENT SPECIFICATION IS CALLED AWS D1.1/D1.1M AND ERECTOR OR FABRICATOR SHOULD BE AWS CERTIFIED WELDING FABRICATOR CERTIFIED UNDER AWS QC17 or AWS B5.17)

INSTALL DOOR MOUNTING CHANNELS
MASONRY BUILDINGS
DIMENSIONS IN PARENTHESIS ARE IN MILLIMETERS

SM-0019

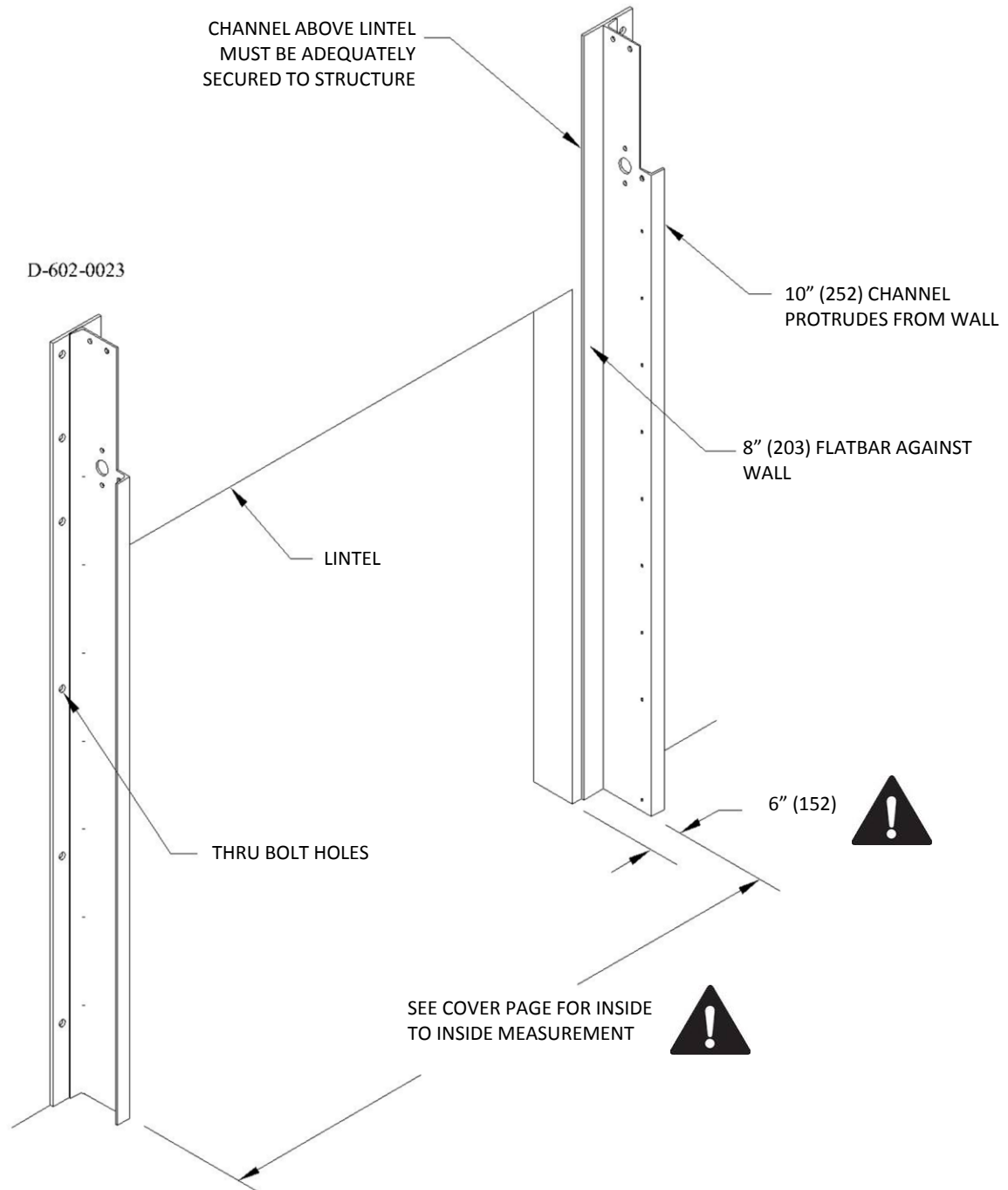

(i) FOR BRICK OR CONCRETE BUILDINGS, STAND THE DOOR MOUNTING CHANNEL AGAINST THE WALL WITH THE 10" (252) CHANNEL PROTRUDING OUTWARD AND THE CHANNEL LEG EXTENDING AWAY FROM THE OPENING.

(ii) WITH THE INSIDE CHANNEL FACE SPACED 6" (152) FROM THE JAMB, FASTEN TO THE WALL WITH APPROPRIATE FASTENERS. THE DOOR MOUNTING CHANNEL MUST BE INSTALLED PLUMB WITHIN 1/4" (6). APPROPRIATE FASTENERS ARE MINIMUM 1/2" (12) DIAMETER WEDGE ANCHORS FOR SOLID CONCRETE AND MINIMUM 1/2" (12) DIAMETER THREADED ROD, THRU BOLTED FOR MOST OTHER MATERIALS, USE APPROPRIATE BACKING PLATES FOR THRU BOLTING. CONSULT A STRUCTURAL ENGINEER TO DETERMINE THE APPROPRIATE METHOD TO FASTEN THE DOOR TO THE BUILDING.

(iii) INSTALL THE SECOND DOOR MOUNTING CHANNEL USING A HORIZONTAL MEASUREMENT BETWEEN THE INSIDE SURFACES OF THE TWO CHANNEL FACES. THIS MEASUREMENT MUST BE THE MANUFACTURED OPENING WIDTH PLUS 12". CONFIRM THIS MEASUREMENT ON 48" VERTICAL INCREMENTS UP THE LENGTH OF THE CHANNEL.

(iv) THE DOOR MOUNTING CHANNEL MUST BE SUPPORTED ABOVE THE LINTEL. IF MOUNTING STRUCTURE DOES NOT EXIST, INSTALL ADEQUATE BRACING.

Bearing Torque Requirement

Dimensions in parenthesis are in millimeters



Notice:
ALL BEARINGS TO BE TORQUED TO 60 FT. LBS.
OVER TORQUING CAN LEAD TO FAILURE OF BEARINGS

Types of Bearing

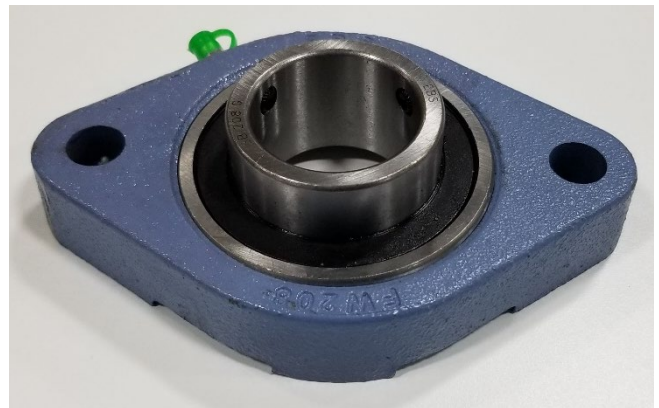

INSTALL IDLER BARREL
DIMENSIONS IN PARENTHESIS ARE IN MILLIMETERS

SM-0022

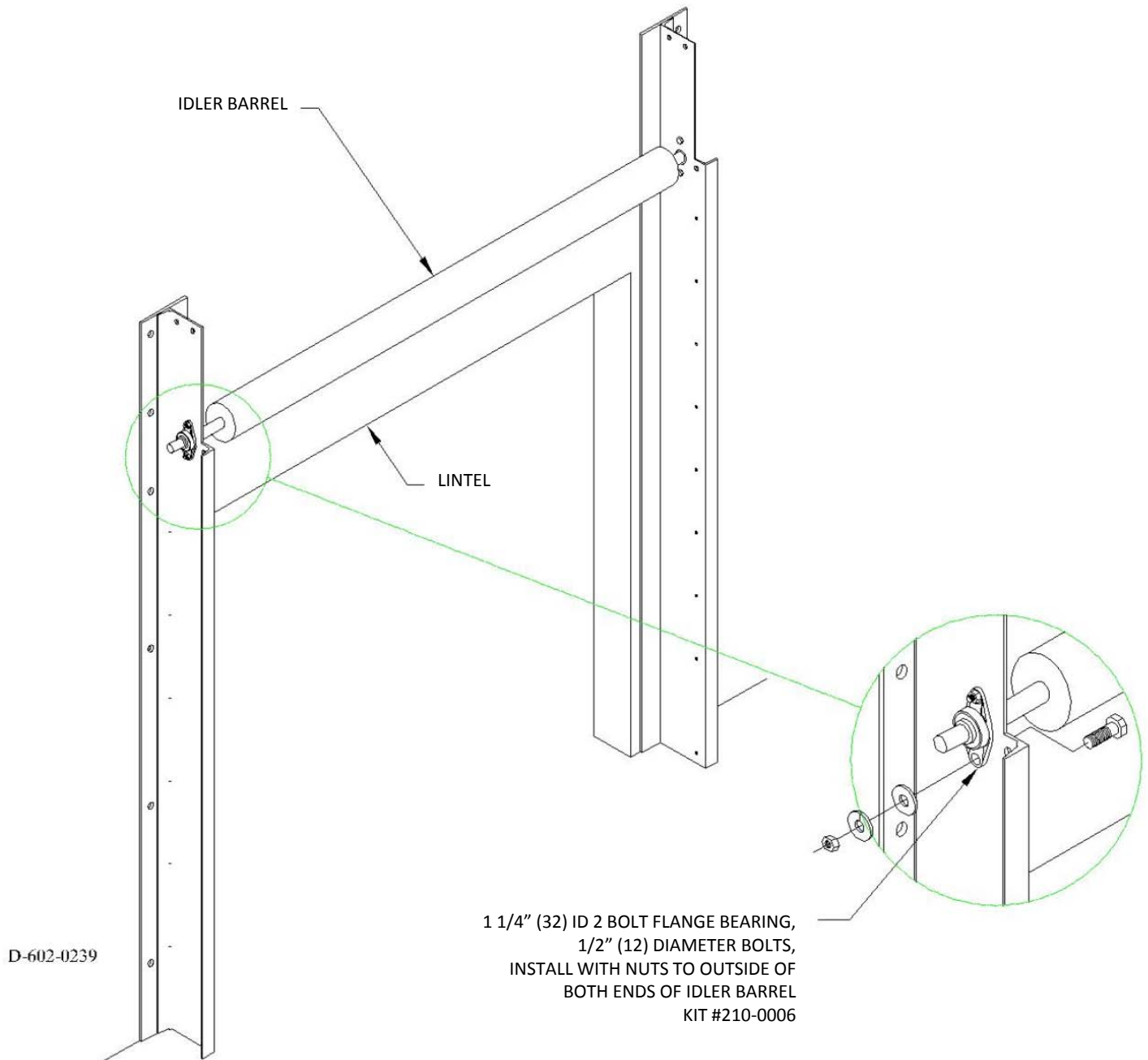

(i) POSITION THE IDLER BARREL BY PLACING THE SHAFT ENDS THROUGH THE 2 1/2" (64) DIAMETER HOLE IN EACH DOOR MOUNTING CHANNEL.

(ii) SLIDE 1-1/2" (38) ID 2 BOLT FLANGE BEARING ONTO EACH END OF THE IDLER BARREL AND FASTEN TO THE DOOR MOUNTING ANGLE USING 1/2" (12) DIAMETER BOLTS, KIT NUMBER 210-0006. INSTALL THE NUTS TO THE OUTSIDE OF THE MOUNTING ANGLES.

(iii) CENTRE THE IDLER BARREL AND TIGHTEN THE SET SCREWS.

INSTALL LINTEL SEAL
DIMENSIONS IN PARENTHESIS ARE IN MILLIMETERS

SM-0027
 Rev. A

DOOR MODEL	DIM "X"
HDXL6, HDXL 7	26 5/16" (668)
HDXL8	28 5/16" (719)

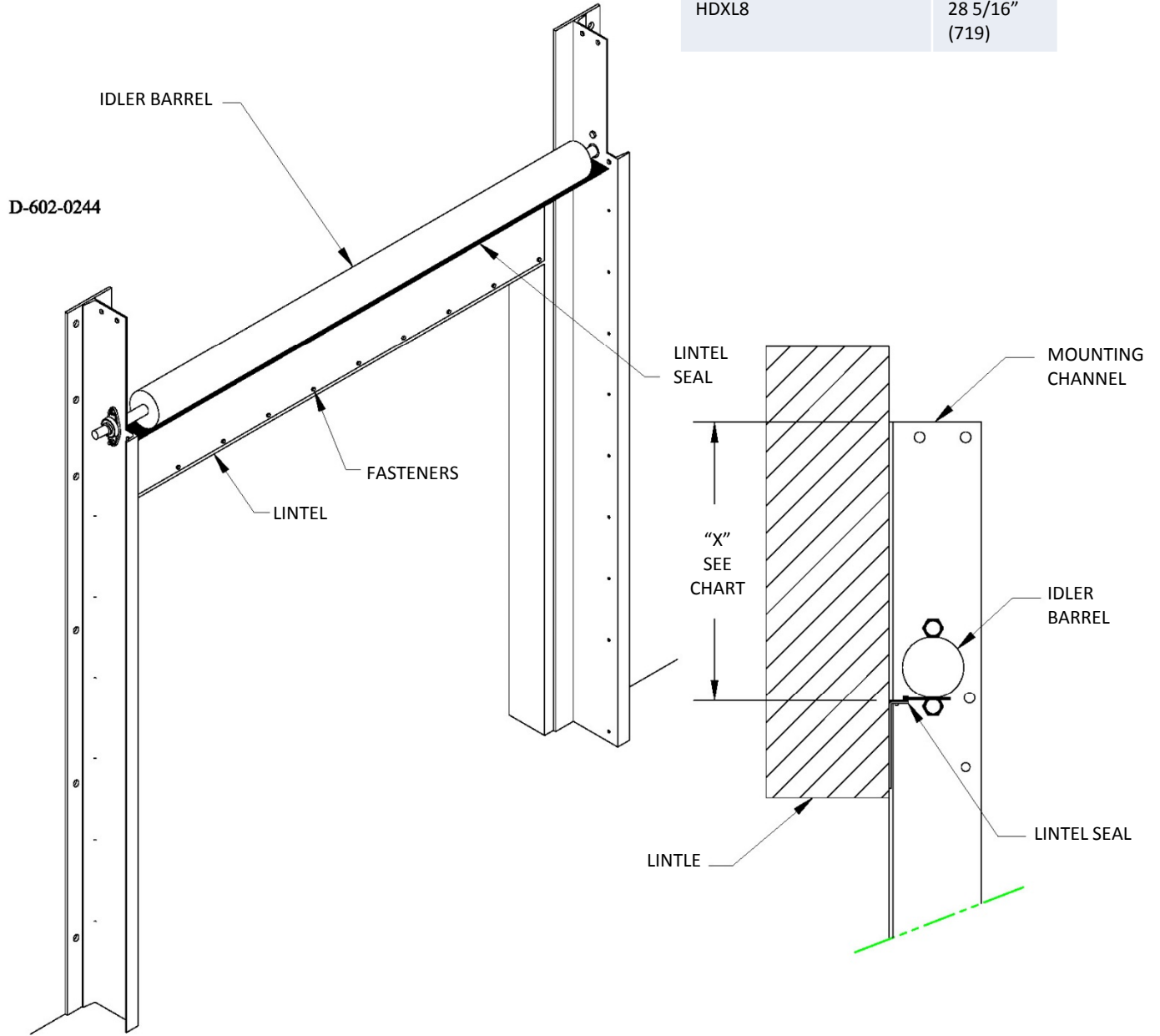

(i) POSITION THE LINTEL SEAL AGAINST THE HEADER BETWEEN THE TWO (2) DOOR MOUNTING CHANNELS.
 (THE LINTEL SEAL IS FABRICATED IN MULTIPLE PIECES ON WIDE DOORS)

(ii) MEASURE DOWN FROM THE TOP OF THE MOUNTING ANGLE TO POSITION THE LINTEL SEAL. THE BRUSH SHOULD JUST TOUCH THE BOTTOM OF THE IDLER BARREL

(iii) FASTEN THE RETAINER TO A STEEL LINTEL WITH THE SELF-TAPPING SCREWS PROVIDED OR APPROPRIATE FASTENERS FOR CONCRETE BULKHEADS ON APPROXIMATELY 18" (460) CENTERS.

INSTALL OPERATOR
DIMENSIONS IN PARENTHESIS ARE IN MILLIMETERS
 LEFT HAND DOOR SHOWN

SM-0029

DOOR MODEL	TOTAL MOVEMENT
HDE, HDT, HDS, HDP, HDC	1/4" (6)
HDL23, HDL45	3/8" (10)
HDXL6	1/2" (12)
HDXL9	5/8" (16)

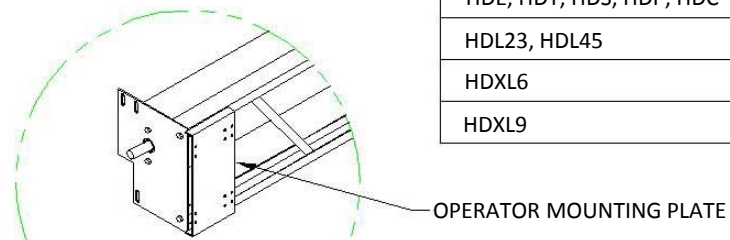
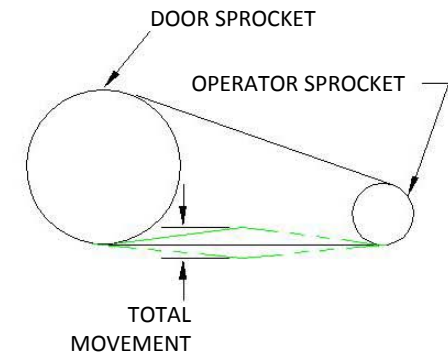

"RG" DRIVE SYSTEM

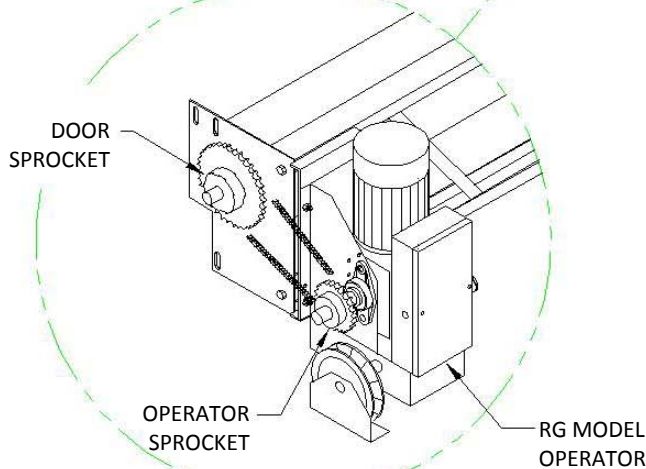

"HG" DRIVE SYSTEM

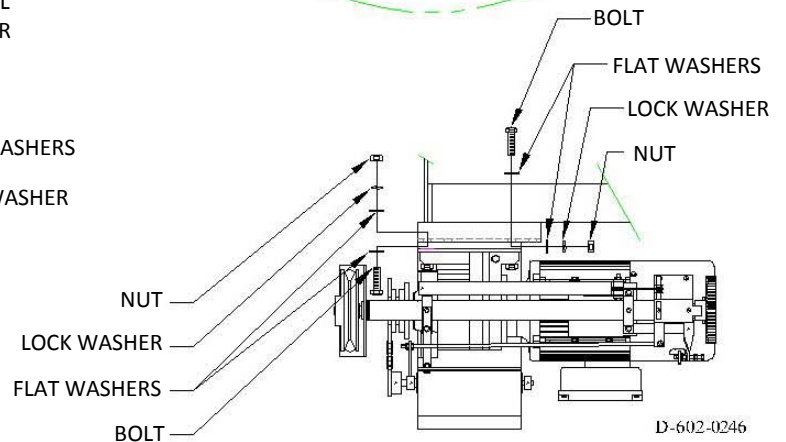
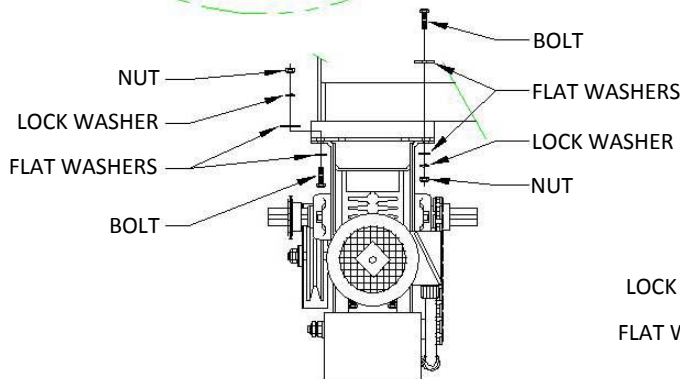
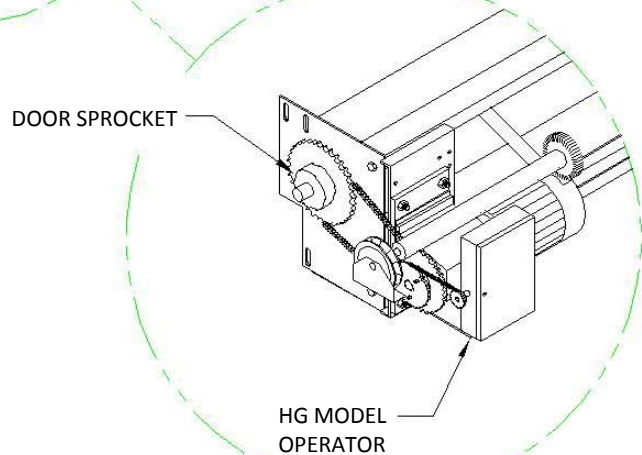

D-602-0246

(i) POSITION AND BOLT THE OPERATOR TO THE MOUNTING PLATE ON THE LOWER SLOT/HOLE SET CLOSEST TO THE ENDPLATE. TIGHTEN THE MOUNTING BOLTS WITH THE OPERATOR COMPLETELY RAISED IN THE ADJUSTMENT SLOTS.

(ii) MOUNT THE DOOR SPROCKET WITH KEYSTOCK TO THE DRIVE BARREL SHAFT WITH THE HUB AWAY FROM THE ENDPLATE. FOR QD SPROCKETS SEE "INSTALLING QD SPROCKETS".



(iii) IF NOT PRE-MOUNTED, MOUNT THE OPERATOR SPROCKET ON THE OPERATOR OUTPUT SHAFT. ALIGN THE SPROCKETS TO EACH OTHER AND AS CLOSE AS POSSIBLE TO THE ENDPLATE. ENSURE ADEQUATE CLEARANCE BETWEEN CHAIN AND MOUNTING PLATE. TIGHTEN SETSCREWS.



(iv) SIZE AND INSTALL THE DRIVE CHAIN. TOTAL SLACK IN THE DRIVE CHAIN IS NOTED IN THE CHART ABOVE. THE SLACK NEEDS TO BE IN THE SECTION OF CHAIN AT THE BOTTOM OF THE SPROCKETS. THE SECTION OF CHAIN AT THE TOP OF THE SPROCKETS SHOULD BE TAUGHT. LOOSEN THE MOUNTING BOLTS AND LOWER THE OPERATOR TO SET CHAIN TENSION. ENGAGE THE ECH AND TURN IT IN BOTH DIRECTIONS TO HELP LOWER THE OPERATOR PROPERLY. TIGHTEN THE OPERATOR MOUNTING BOLTS. DO NOT REMOVE THE ROPES SECURING THE RUBBER CURTAIN TO THE DRIVE BARREL UNTIL INSTRUCTED TO DO SO.

Pre-charge springs

Dimensions in parenthesis are in millimeters
Left hand door shown with model RG operator

SM-0033
Rev. A

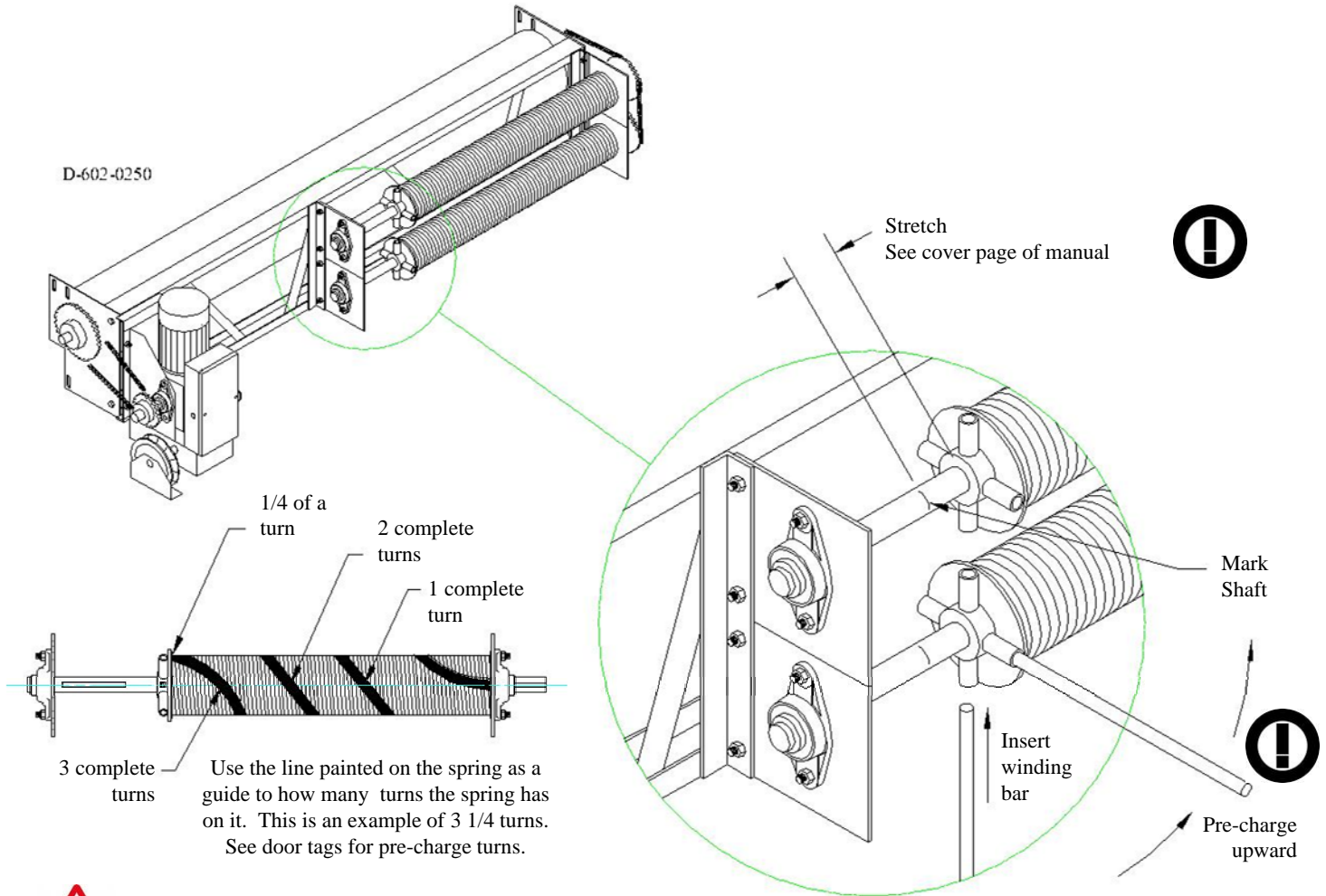

Torsion springs store mechanical energy and can be extremely dangerous. This portion of the installation should be carried out by a qualified door service technician. Do not remove the ropes securing the rubber curtain to the drive barrel until instructed to do so.

- (i) From the door tag, obtain the quantity for both stretch and pre-charge. These quantities apply to each spring assembly on the door regardless of the total number of springs.
- (ii) Assuring the spring is fully compressed, measure the stretch distance (inches) along the shaft from the winding hub. Mark the shaft(s) at this dimension from all winding hubs.
- (iii) Use a 3/4" (19) diameter x minimum 30" (760) long winding bar to rotate the winding hub upwards. Allow the winding hub to slowly rotate backwards from its own energy. The pre-charge turns must be measured from this initial location.
- (iv) If there isn't already a horizontal line on the spring mark a horizontal line along the spring to later reference the number of turns.
- (v) Pre-charge the springs upward the required number of turns (see manual cover page) by alternating two winding bars on 90 degree increments in the winding cone.
- (vi) After completing the pre-charge, stretch the spring to the mark you made on the shaft. Add enough pre-charge to align the next setscrew with the ground flat on the shaft and tighten all setscrews.
- (vii) Complete this procedure with all springs.
- (viii) With pre-charge complete, verify counterbalance by manually oscillating the drive barrel. A proper balance will allow you to alternate the chain tension at the operator from top to bottom. Adjust pre-charge as required.

INSTALL HEADER ASSEMBLY
DIMENSIONS IN PARENTHESIS ARE IN MILLIMETERS
LEFT HAND DOOR SHOWN

SM-0036

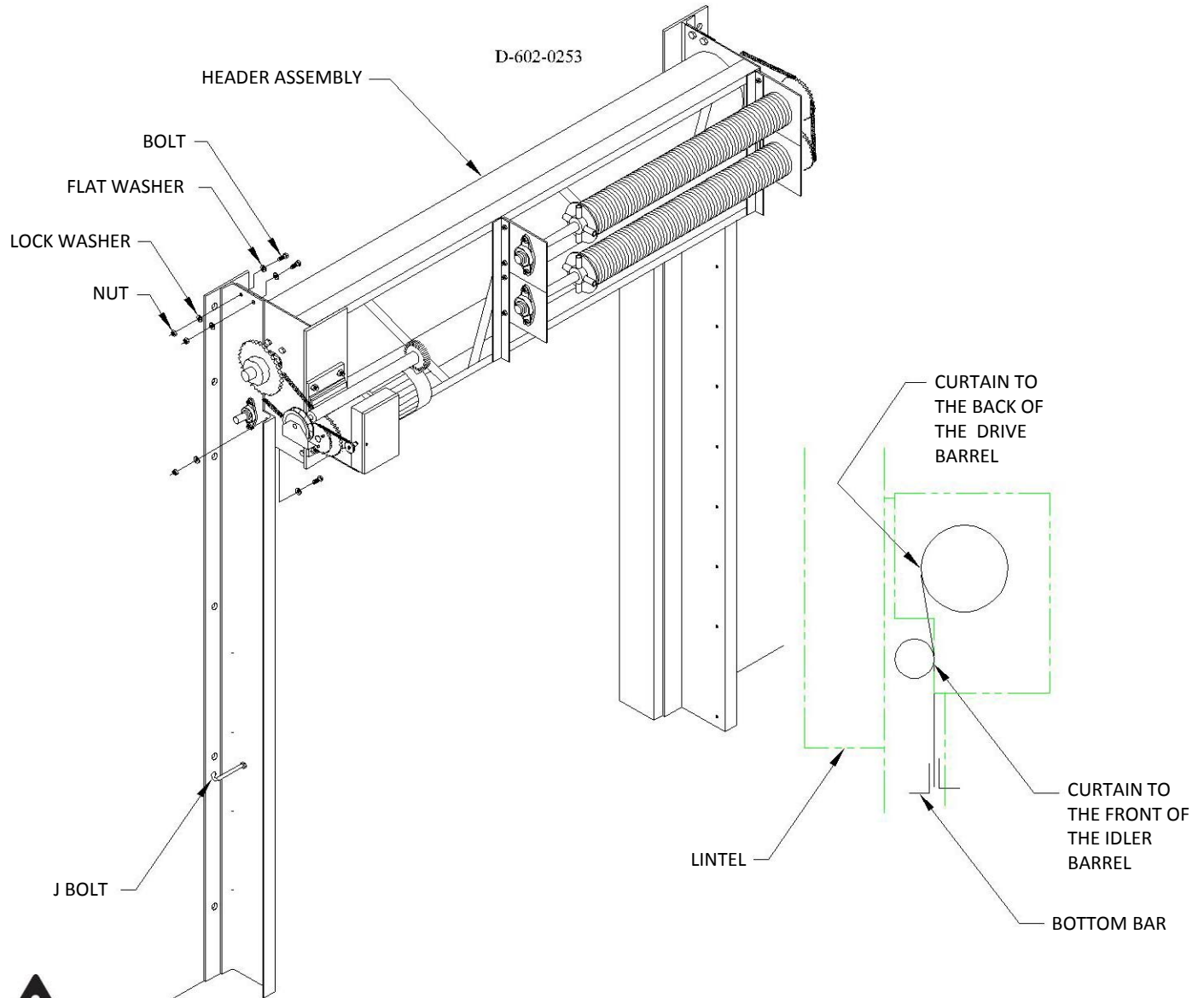

DOOR MUST BE RIGGED BY SLINGING THE DRIVE BARREL. DO NOT LIFT THE DOOR BY THE ENDPLATES.



THE BOTTOM BAR MUST BE ROTATED SLIGHTLY TOWARDS THE TRUSS WHEN RIGGED FOR LIFTING.

(i) POSITION THE HEADER ASSEMBLY ON THE FLOOR IN FRONT OF THE OPENING.



(ii) RIG AND LIFT THE HEADER ASSEMBLY INTO POSITION AND FASTEN TO THE DOOR MOUNTING ANGLE USING HARDWARE KIT 210-0005. INSTALL THE NUTS ON THE OUTSIDE TO PREVENT CURTAIN CONTACT. ALLOW THE ENDPLATES TO SETTLE INTO THE LOWEST POSITION OF THE SLOTS AND PLACE A LEVEL ON THE DRIVE BARREL TO ENSURE THE HEADER IS INSTALLED LEVEL. IF UNLEVEL RAISE OR LOWER THE ENDPLATES IN THE SLOTS AS NECESSARY AND TIGHTEN FASTENERS TO ENSURE THE HEADER IS LEVEL.

(iv) POSITION BOTTOM BAR AT THE BOTTOM OF THE DRIVE BARREL WHEN REMOVING THE RIGGING STRAPS.

(v) INSTALL THE HAND CHAIN AND DISCONNECT LEVER. DO NOT ENGAGE UNLESS THE SPRINGS HAVE BEEN CHARGED.

(vi) INSTALL THE "J" BOLT ON THE DOOR MOUNTING ANGLE (HOLE PROVIDED) ABOUT 48" (1220) FROM THE FLOOR. THE "J" BOLT IS TO PROTRUDE AWAY FROM THE DOOR OPENING TO ALLOW THE HAND CHAIN TO BE HELD CLEAR OF THE DOOR DURING ELECTRICAL OPERATION.

(vii) REMOVE THE ROPES SECURING THE CURTAIN TO THE DRIVE BARREL. REMAIN CLEAR OF THE BOTTOM BAR AS IT FALLS INTO POSITION AGAINST THE FORWARD SIDE OF THE IDLER BARREL.

FDGH Brake Release Adjustment

Dimensions in parenthesis are in millimeters

SM-0439
Rev. A.



Failure to follow Brake Release Adjustment Procedure may result in Injury or Death.

Notice

Excessively releasing the brake while the chain hoist is engaged, will cause the gears to stick. If this occurs, wiggling the hand chain will disengage the gears. Refer to step 1 below to continue with the adjustment procedure

The adjustment of the brake release keeps the operator's brake partially engaged, while releasing the brake slightly to ensure proper operation of the chain hoist. Such a brake adjustment will maintain the door if the hand chain is released.

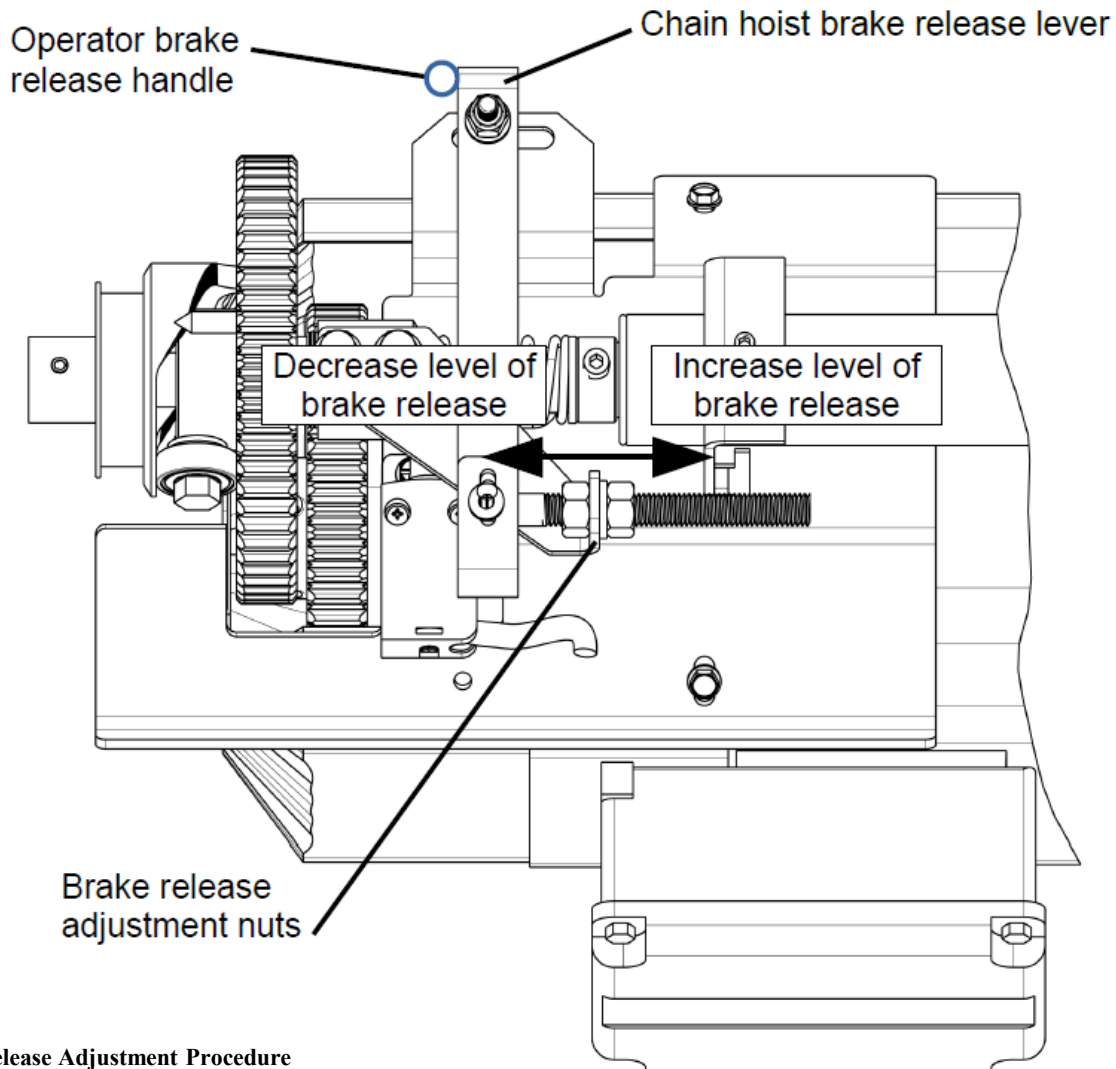

Brake Release Adjustment Procedure

1. Make sure the door is in the fully closed position.
2. Unscrew the brake release's adjustment nuts. Move the adjustment bolt towards the gears to adjust the brake release so that the brake is **NOT** released when the chain hoist is engaged. Tighten the nuts. **At this point, the chain hoist will NOT be able to move the door.**
3. Unscrew the brake release's adjustment nuts. Slowly move (by small increments) the bolt towards the motor until the brake is partially released. **At this point, the door will be difficult to move with the chain hoist.**
4. Repeat step 3 until the door can be moved by the chain hoist. Make sure that the chain hoist releases by itself when the hand chain is released. **Make sure that the brake is only released when the chain hoist is engaged.**
5. Tighten the brake release's adjustment nuts.

INSTALL ALUMINUM GUIDES
DIMENSIONS IN PARENTHESIS ARE IN MILLIMETERS
LEFT HAND DOOR SHOWN

SM-0044

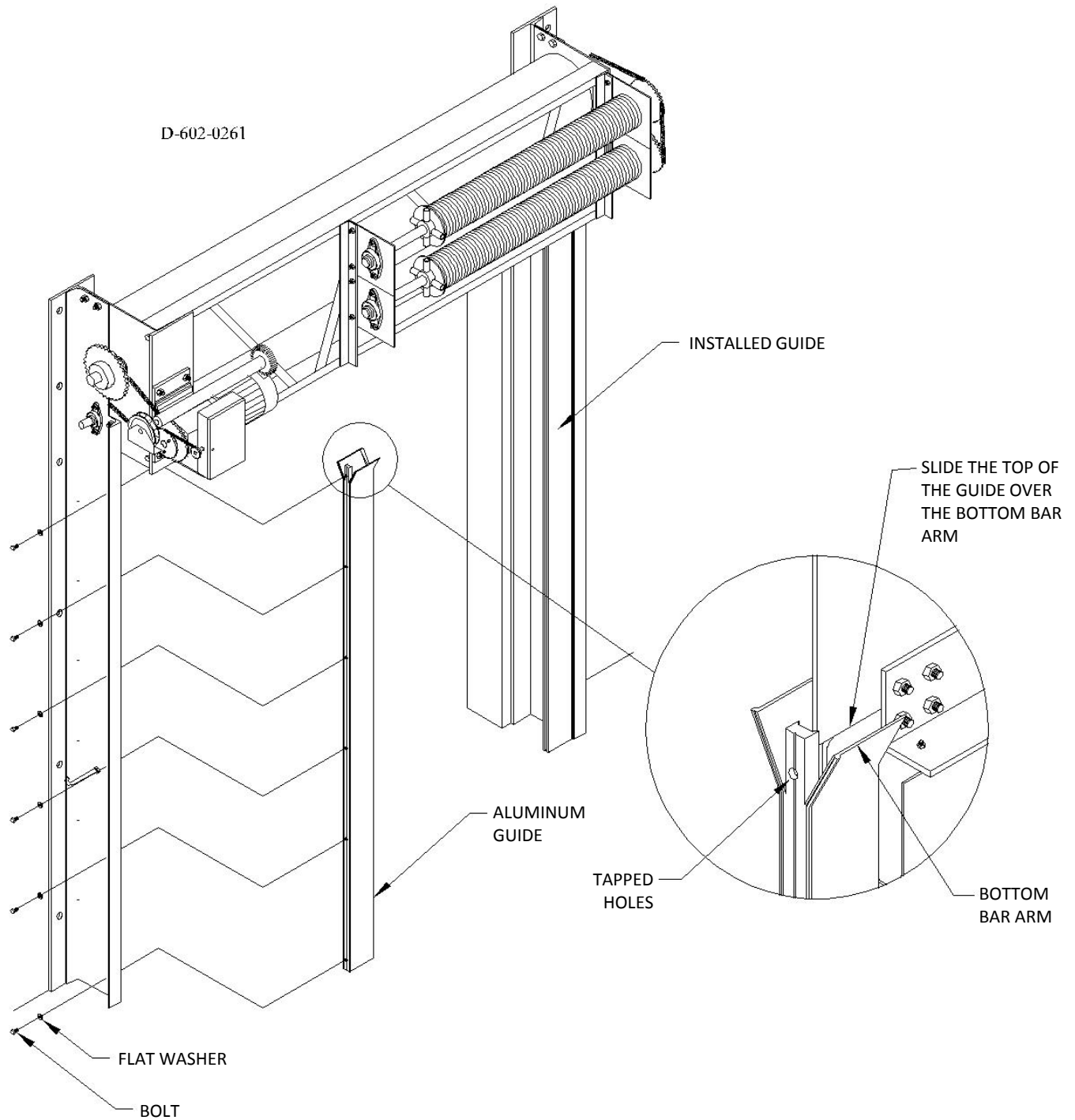

DO NOT INSTALL LONGER BOLTS INTO THE GUIDE. LONGER BOLTS WILL PROTRUDE INTO THE GUIDE CAVITY AND INTERFERE WITH CURTAIN TRAVEL.

- (i) BOTH GUIDES ARE INTERCHANGEABLE BETWEEN THE LEFT AND RIGHT HAND SIDE.
- (ii) INSTALL THE GUIDES WITH THE FLARED ENDS TO THE TOP. SLIDE THE TOP OF THE GUIDE OVER THE BOTTOM BAR ARM TO CAPTURE THE BOTTOM CORNER OF THE CURTAIN. POSITION THE GUIDE TO THE DOOR MOUNTING ANGLE.
- (iii) FASTEN THE GUIDE TO THE MOUNTING ANGLE USING SUPPLIED HEX HEAD BOLTS AND FLAT WASHERS. KIT 210-0011.

INSTALL LIGHT CURTAINS
DIMENSIONS IN PARENTHESIS ARE IN MILLIMETERS
 LEFT HAND SPRUNG DOOR WITH RG OPERATOR SHOWN

SM-0053
 Rev. A

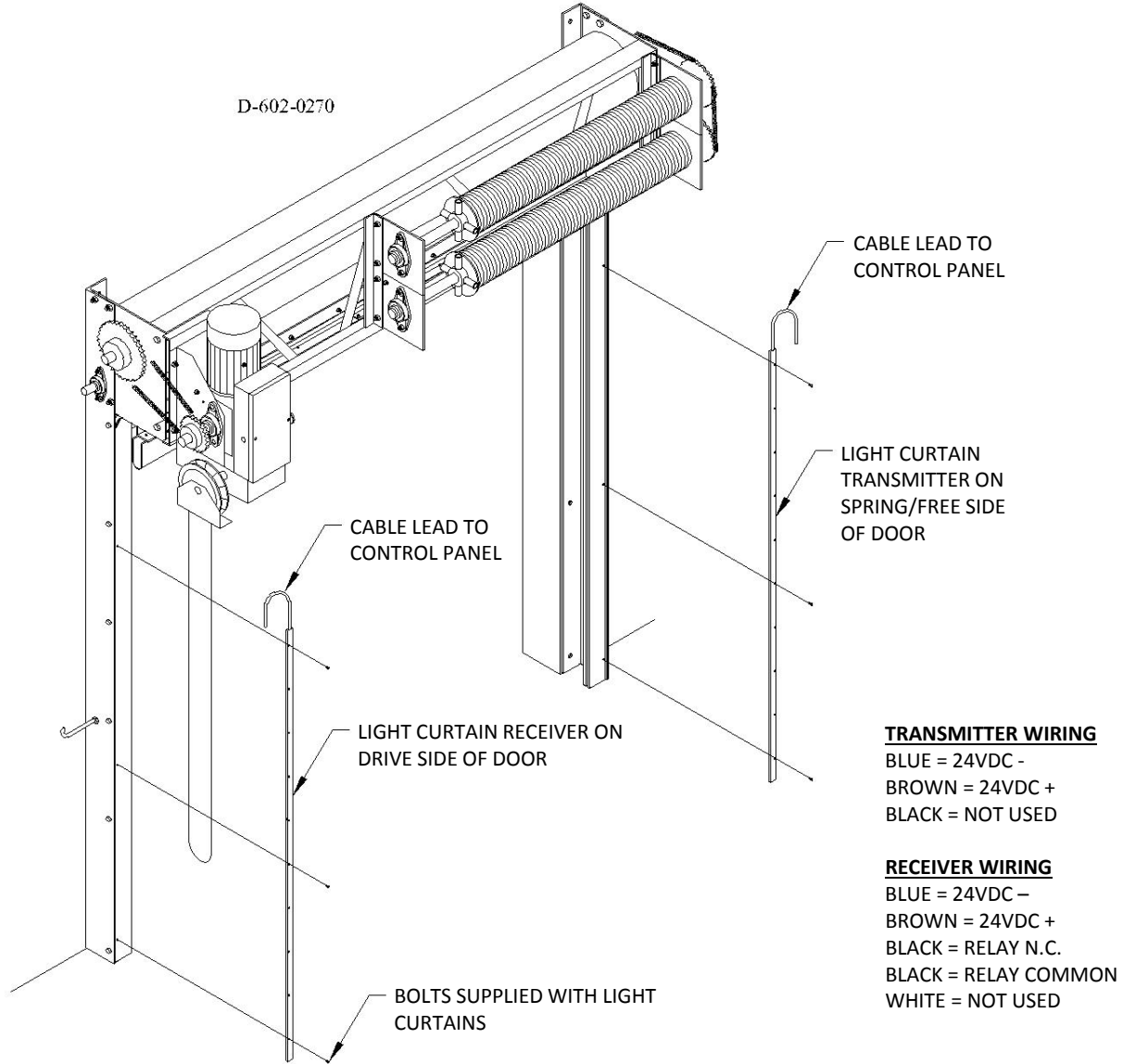

LIGHT CURTAINS MUST BE INSTALLED SQUARE TO THE OPENING ON THE INTERIOR SIDE OF THE DOOR AND PARALLEL TO EACH OTHER TO ENSURE PROPER ALIGNMENT

INSTALL LIGHT CURTAINS PRIOR TO INSTALLING GUIDE GUARDS.

(i) FASTEN THE LIGHT CURTAIN RECEIVER, WITH THE CABLE AT THE TOP OF THE UNIT, TO THE ALUMINIUM GUIDE ON THE DRIVE SIDE OF THE DOOR USING THE SUPPLIED BOLTS.

(ii) FASTEN THE LIGHT CURTAIN TRANSMITTER, WITH THE CABLE AT THE TOP OF THE UNIT, TO THE ALUMINIUM GUIDE ON THE SPRING/FREE END SIDE OF THE DOOR USING THE SUPPLIED BOLTS.

(iii) WIRE THE RECEIVER TO THE CONTROL PANEL AS INDICATED ON THE WIRING SCHEMATIC FOR THE DOOR. CAP ANY UNUSED WIRES SEPARATELY.

(iv) WIRE THE TRANSMITTER TO THE CONTROL PANEL AS INDICATED ON THE WIRING SCHEMATIC FOR THE DOOR. CAP ANY UNUSED WIRES SEPARATELY.



THE MOUNTING LOCATION OF THE LIGHT CURTAIN(S), MOUNTING HEIGHT, DISTANCE FROM THE DOOR, QUANTITY AND WHICH SIDE OF THE DOOR THE LIGHT CURTAIN IS ON, IS TO BE DETERMINED BY THE INSTALLER BASED ON THE TYPE OF TRAFFIC USING THE DOOR, WHICH SIDE OF THE DOOR THE TRAFFIC IS APPROACHING FROM, THE SPEED OF THE TRAFFIC, DOOR SPEED, AND FACTORS. TNR IS NOT RESPONSIBLE FOR IMPROPER PHOTOCELL PLACEMENT OR WIRING. THE PHOTOCELL SUPPLIED WITH THE DOOR IS INTENDED AS A REVERSING DEVICE.



INSTALL GUIDE GUARDS
DIMENSIONS IN PARENTHESIS ARE IN MILLIMETERS

SM-0048

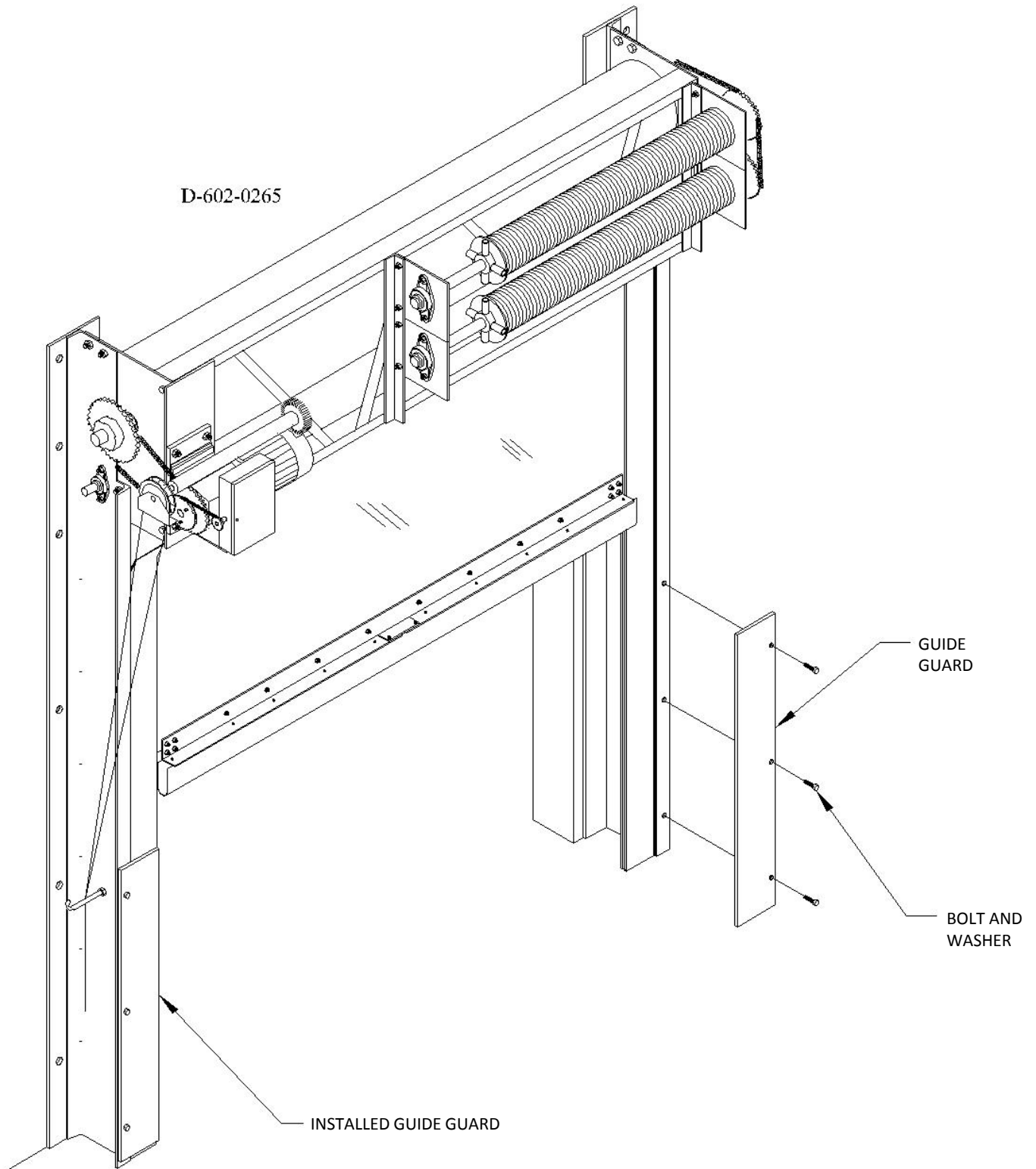

(i) POSITION THE GUIDE GUARD WITH THE THREE (3) MOUNTING HOLES ALIGNED WITH THE TAPPED HOLES IN THE CHANNEL LEG OF THE DOOR MOUNTING CHANNEL. THE LONG LEG OF THE GUIDE GUARD PROTRUDES TOWARDS THE OPENING, SHIELDING THE ALUMINUM GUIDE.

ii) USE THE FASTENERS IN THE GUIDE GUARD HARDWARE KIT TO FASTEN THE GUARDS TO THE DOOR MOUNTING CHANNEL.

Install guide mounted windbar

Dimensions in parenthesis are in millimeters

Left hand door shown

SM-0049

Rev. B

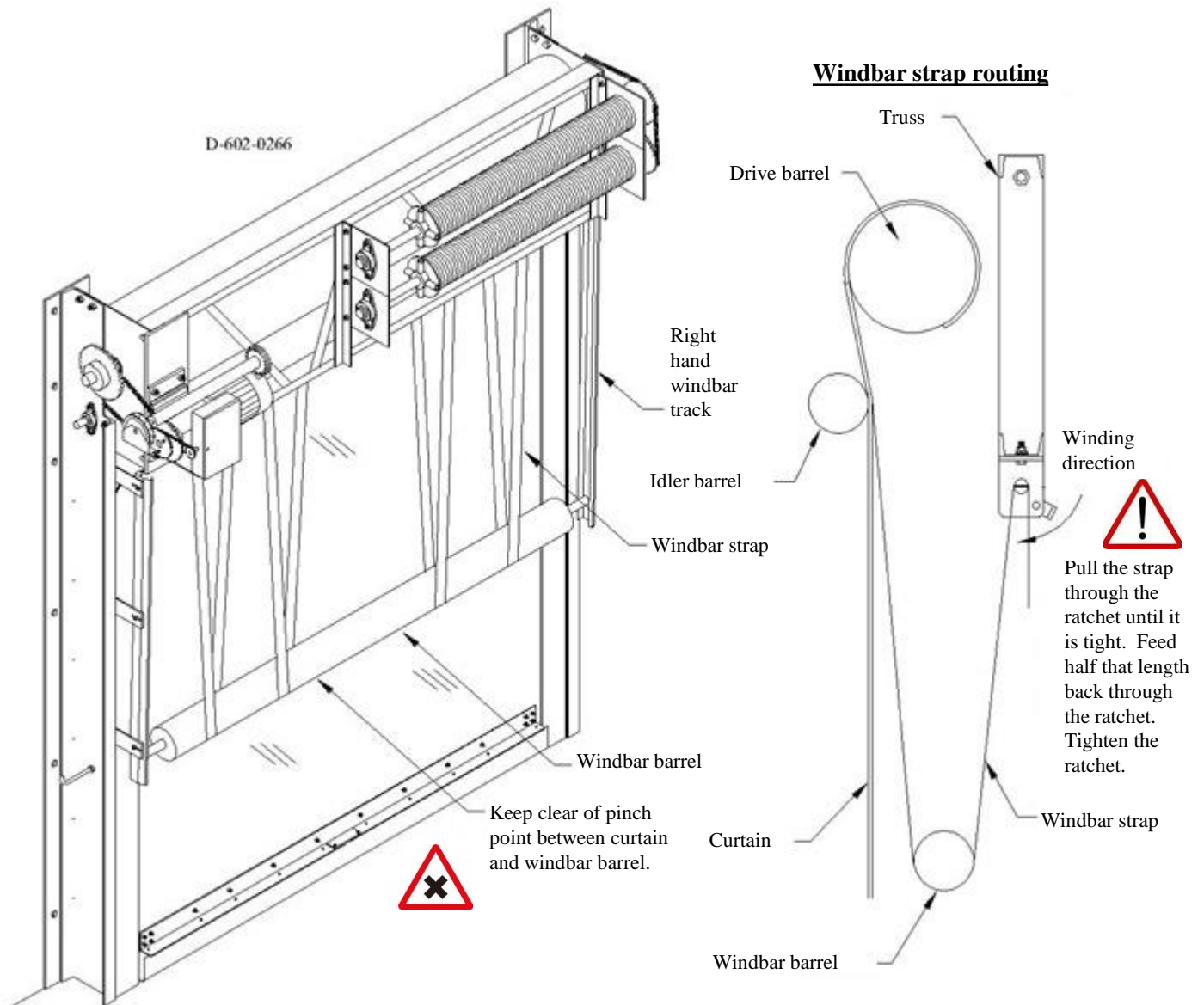

- (i) Position the left and right windbar tracks to the inside of the track Brackets on the door mounting channel. The curved side of the windbar track must be away from the curtain and the stop bolts at the bottom.
- (ii) Bolt the tracks to the brackets using the button head cap screws with lockwasher and nut. Adjust the tracks close to the curtain at the bottom and tapered away from the curtain at the top.
- (iii) Mount the four ratchet buckles to the bottom of the truss with the provided bolts with flatwasher, lockwasher and nut. Orient the ratchet buckle with the release handle outward.
- (iv) With the door in the fully closed position, insert a roller into each end of the windbar barrel and lift the barrel into the bottom of the roller tracks. Close off the bottom of each track with a 3" (76) lg. Bolt with nut.
- (v) Feed the windbar strap between the curtain and windbar barrel, around the bottom of the barrel and up to the ratchet buckles on the truss. Assure there are no twists in the windbar straps.
- (vi) Attach the straps to the ratchets as shown. With the windbar sitting on the track stops, pull the strap tight then feed 8" (203) – 12" (304) back through the ratchet allowing the strap to go loose under the windbar. Turn the ratchet until the windbar is now 2" (50) above the track stops. Assure the windbar barrel is level.
- (vii) Carefully cycle the door to the open position. Use the ratchets to adjust the windbar barrel location so that it stops above the lintel to provide the full clear opening when the door is fully open.

Install jamb mounted windbar

Dimensions in parenthesis are in millimeters

Left hand door shown

SM-0050
Rev. B

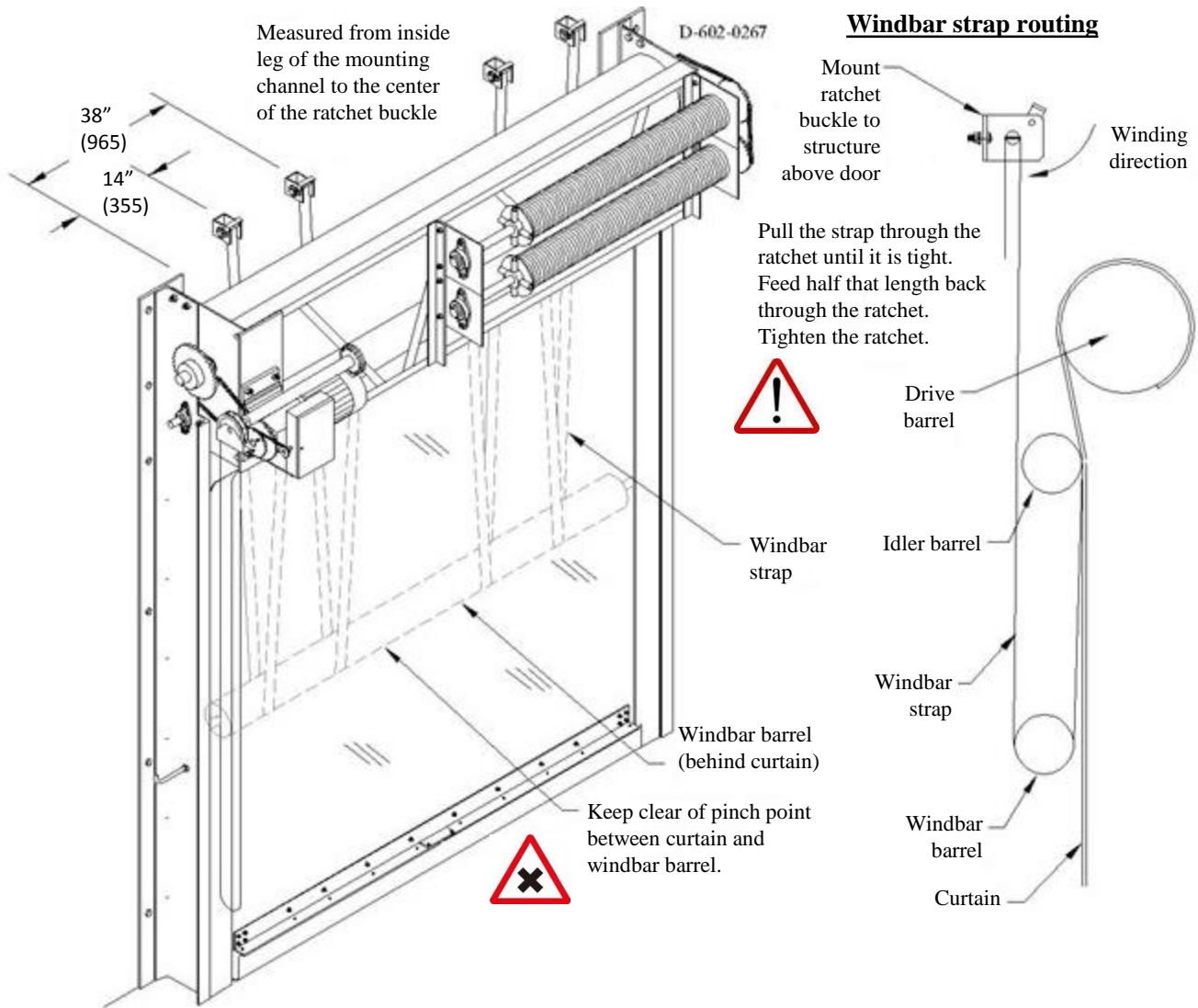

(i) Orient the left and right windbar tracks to the inside of the door mounting channel. The curved side of the windbar track must be away from the curtain and the stop bolts at the bottom.

(ii) bolt the tracks to the door mounting channel using the button head cap screws with lockwasher and nut.

(iii) Mount the four ratchet buckles above the header assembly and at dimensions shown from the door mounting channel. Orient the ratchet buckle with the release handle upward. If the door was ordered with hoods, the ratchet buckles are premounted to the wall bracket (see hood installation).

(iv) From the ratchet buckle location, feed a "fish" line down the wall behind both the drive barrel and idler barrel. The lintel brush holder has been notched to facilitate the straps.

(v) With the door in the fully closed position, insert a roller into each end of the windbar barrel and lift the barrel into the bottom of the roller tracks. Close off the bottom of each track with a 3" (76) lg. Bolt with nut.

(vi) Feed the windbar strap between the curtain and windbar barrel, around the bottom of the barrel and up to the ratchet buckles on the wall using the "fish" line. Assure there are no twists in the windbar straps.

(vii) Attach the straps to the ratchets as shown. With the windbar sitting on the track stops, pull the strap tight then feed 8" (203) – 12" (304) back through the ratchet allowing the strap to go loose under the windbar. Turn the ratchet until the windbar is now 2" (50) above the track stops. Assure the windbar barrel is level.



(viii) Carefully cycle the door to the open position. Use the ratchets to adjust the windbar barrel location so that it stops above the lintel to provide the full clear opening when the door is fully open.

MANUAL CHECK OF OPERATIONS
DIMENSIONS IN PARENTHESIS ARE IN MILLIMETERS
SPRUNG DOOR WITH RG OPERATOR SHOWN

SM-0054

D-602-0271

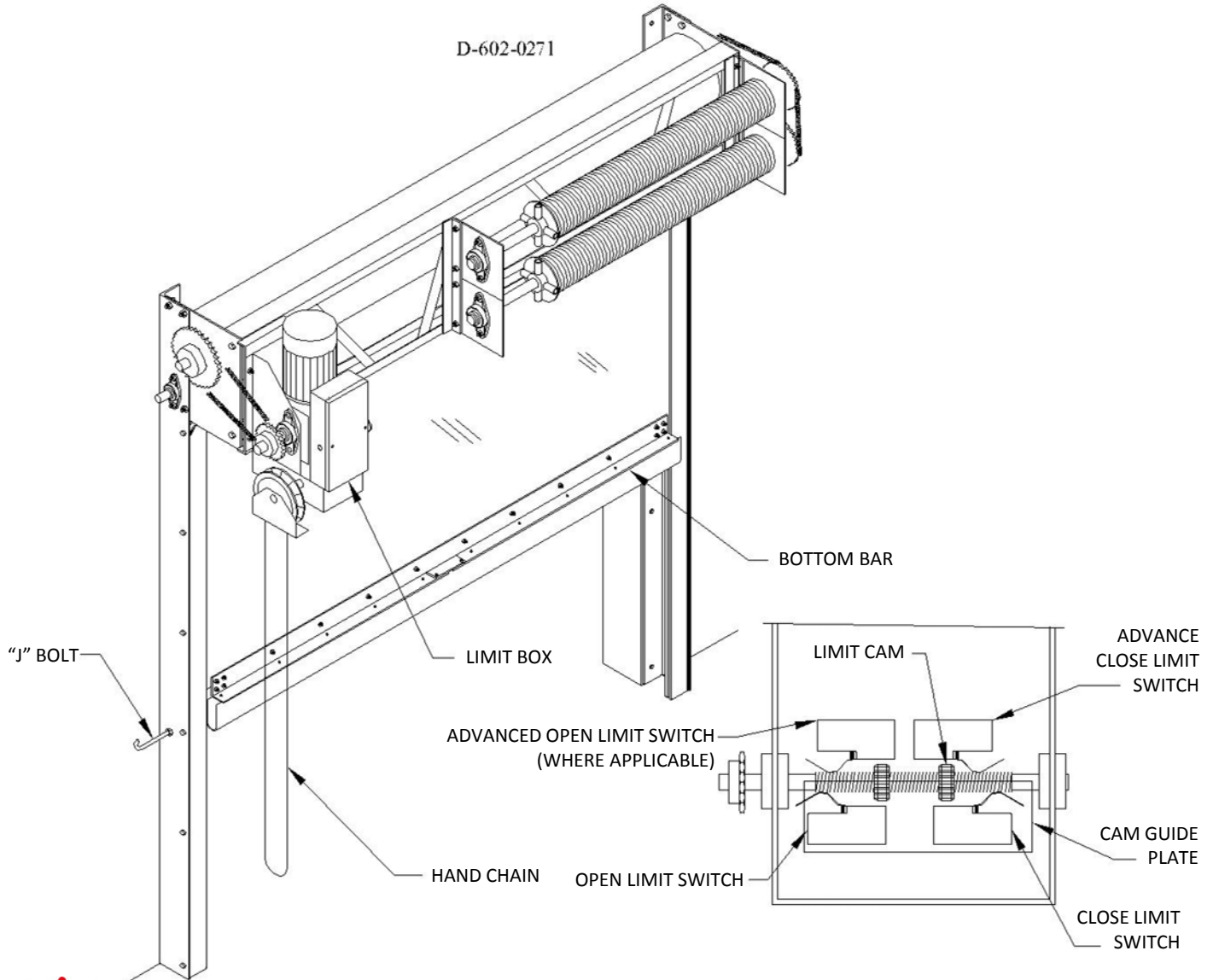

ALWAYS ENSURE THE DOOR'S POWER SUPPLY IS LOCKED OUT WHEN SETTING THE LIMITS TO ENSURE IT CAN'T START UP WHILE WORKING NEAR OR ON THE OPERATOR



ASSURE THE LIMIT CAMS DO NOT ENGAGE AND DAMAGE LIMIT SWITCHES DURING MANUAL CHAIN HOIST OPERATION.

(i) OPEN THE LIMIT BOX COVER ON THE FRONT OF THE OPERATOR. ROTATE THE LIMIT CAMS AWAY FROM THE CLOSE LIMIT SWITCHES TO PREVENT CONTACT DURING MANUAL OPERATION.

(ii) ENGAGE THE MANUAL CHAIN HOIST AND LOWER THE DOOR TO THE FULLY CLOSED POSITION. CHECK FOR PROPER CURTAIN TRACKING WHILE CYCLING THE DOOR.

(iii) WITH THE BOTTOM BAR ABOUT 24" (600) FROM THE FLOOR, ADJUST THE CLOSE LIMIT CAM TO CONTACT THE CLOSE LIMIT SWITCH.

(iv) USE THE MANUAL CHAIN HOIST TO CYCLE THE DOOR TO THE OPEN POSITION. WITH THE BOTTOM BAR ABOUT 24" (600) BELOW THE HEADER, ADJUST THE OPEN LIMIT CAM TO ENGAGE THE OPEN LIMIT SWITCH.

(v) DISENGAGE THE CHAIN HOIST AND HOOK THE HAND CHAIN BEHIND THE "J" BOLT TO HOLD THE CHAIN CLEAR OF THE OPENING.



OPEN AND CLOSE LIMIT SWITCH'S ARE FIXED IN POSITION. THE ADVANCE OPEN AND CLOSE LIMIT SWITCH'S ARE ADJUSTABLE BY LOOSENING THEIR MOUNTING BOLTS AND SLIDING THEM IN THE SLOTS IN THE WHITE BACKING PLATE. THE ADVANCE CLOSE SWITCH SHUTS OFF THE REVERSING EDGE BEFORE THE DOOR CONTACTS THE FLOOR. WHEN THE CONTROL PANEL IS EQUIPPED WITH A VARIABLE FREQUENCY DRIVE THE ADVANCE OPEN AND CLOSE DETERMINE WHERE THE SOFT STOP (SLOW DOWN) BEGINS.

HOOD INSTALLATION

SM-0088

LEFT HAND DOOR SHOWN

DIMENSIONS IN PARENTHESIS ARE IN MILLIMETERS

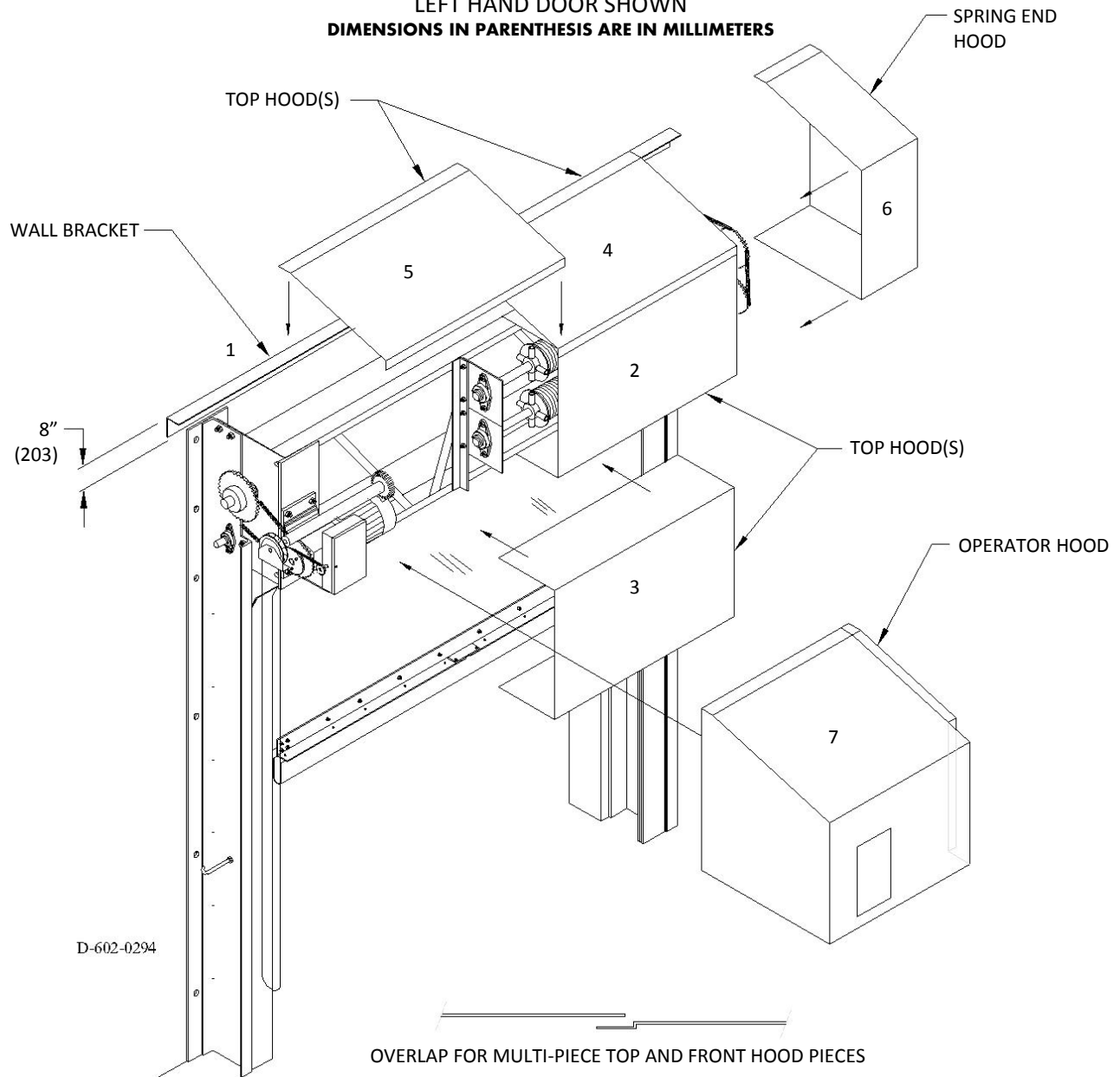

(i) INSTALL THE WALL BRACKET ONTO THE WALL WITH THE TOP 3" (76) LEG 8" (203) ABOVE THE TOP OF THE ENDPLATES. THE BRACKET SHOULD EXTEND EVENLY BEYOND THE ENDPLATE AT EACH END. THE WALL BRACKET IS FABRICATED IN MULTIPLE PIECES ON WIDE DOORS.

(ii) BEGINNING AT THE SPRING END, INSTALL THE FRONT HOODS OVER THE SPRINGS AND FASTEN TO THE TOP AND BOTTOM OF THE DOOR TRUSS WITH THE SUPPLIED SELF-TAPPING SCREWS. THE FIRST HOOD IS MOUNTED FLUSH WITH THE ENDPLATE. MULTI-PIECE HOODS HAVE PROVISIONS FOR A 1" (25) OVERLAP PER SEAM.

(iii) FALSE SUPPORT PLATES HAVE BEEN PROVIDED WHERE THE HOOD MUST EXTEND PAST THE LAST SPRING SUPPORT PLATE.

(iv) INSTALL THE TOP HOODS STARTING FLUSH WITH THE SPRING ENDPLATE. MULTI-PIECE HOODS HAVE PROVISIONS FOR A 1" (25) OVERLAP PER SEAM. INSTALL THE SUPPLIED SELF TAPPING SCREWS WHERE HOLES ARE PROVIDED.

(v) INSTALL THE SPRING END HOOD OVER THE SPRING CHAINS. ALLOW A 2" (54) OVERLAP ONTO THE DOOR HOODS. INSTALL THE SUPPLIED SELF TAPPING SCREWS WHERE HOLES ARE PROVIDED.

(vi) INSTALL THE OPERATOR HOOD IN THE SAME MANNER AS THE SPRING END HOOD. REMOVE THE HOOD ACCESS COVER TO ALIGN THE ACCESS HOLE WITH THE LIMIT BOX COVER.



(vii) SEAL ALL JOINTS AND BETWEEN THE WALL BRACKET AND THE BUILDING TO PREVENT WATER INTRUSION.

INSTALLING PHOTOCELLS
DIMENSIONS IN PARENTHESIS ARE IN MILLIMETERS

SM-0057

D-602-0274

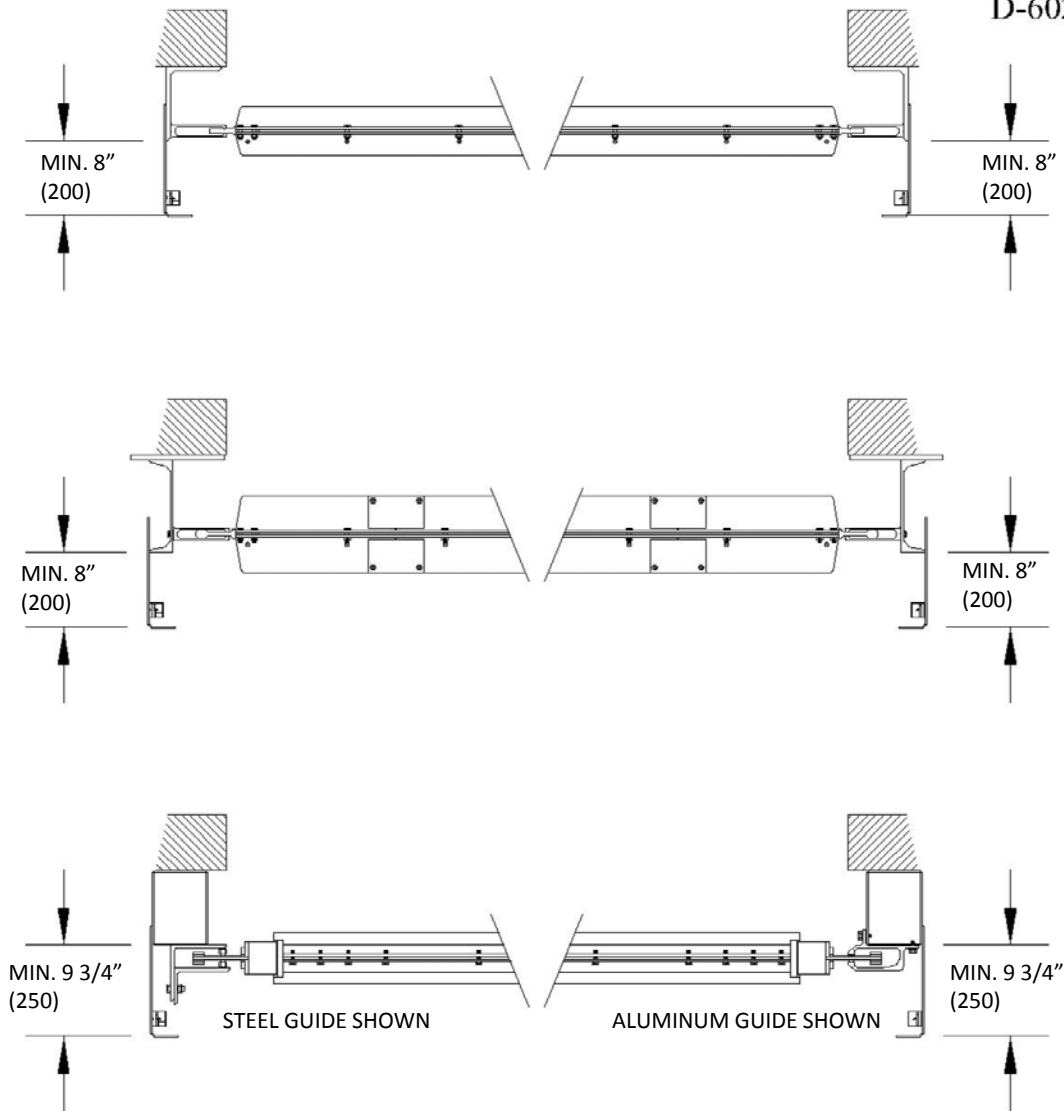

NOTE WHICH MOUNTING CONFIGURATION YOUR DOOR HAS TO DETERMINE THE MINIMUM PHOTOCELL CLEARANCE DIMENSION

(i) MOUNT THE PHOTOSWITCH BRACKETS TO THE DOOR MOUNTING ANGLE AT AN APPROPRIATE ELEVATION FOR THE DOOR USAGE. THE BRACKETS MUST PROTRUDE AS INDICATED ABOVE TO CLEAR THE MOVEMENT OF THE DOOR. THE BRACKETS MAY BE WELDED OR DRILL AND FASTEN IF PREFERRED.



(ii) THE HEIGHT OF THE PHOTOCELLS IS DETERMINED BY THE TYPE OF TRAFFIC THAT PASSES THROUGH THE DOOR. THE PHOTOCELL SHOULD ALIGN WITH THE FIRST PART OF THE VEHICLE THAT WILL PASS THROUGH THE DOOR. EXAMPLE, IF CARS WILL BE PASSING THROUGH THE OPENING ALIGN THE PHOTOCELLS WITH THE BUMPERS OF THE CAR.

(iii) WIRE THE PHOTOCELLS TO THE CONTROLS AS A REVERSING DEVICE.



THE MOUNTING LOCATION OF THE PHOTOCELL(S), MOUNTING HEIGHT, DISTANCE FROM THE DOOR, QUANTITY AND WHICH SIDE OF THE DOOR THE PHOTOCELL IS ON, IS TO BE DETERMINED BY THE INSTALLER BASED ON THE TYPE OF TRAFFIC USING THE DOOR, WHICH SIDE OF THE DOOR THE TRAFFIC IS APPROACHING FROM, THE SPEED OF THE TRAFFIC, DOOR SPEED, AND OTHER FACTORS. TNR IS NOT RESPONSIBLE FOR IMPROPER PHOTOCELL PLACEMENT OR WIRING. THE PHOTOCELL SUPPLIED WITH THE DOOR IS INTENDED AS A REVERSING DEVICE.



**INSTALL MONITORED PHOTOEYES
DIMENSIONS IN PARENTHESIS ARE IN MILLIMETERS**

SM-0123
Rev. A

1) THE RECEIVER ADAPTER HAS A PLASTIC LENS THAT MUST BE USED ON THE RECEIVER SENSOR.

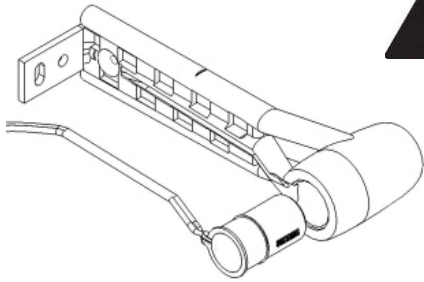

INSTALL PHOTOCELL RECEIVER IN FLEXIBLE ADAPTER MARKED RECEIVER

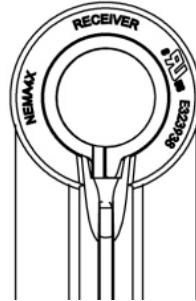

INSTALL PHOTOCELL TRANSMITTER IN FLEXIBLE ADAPTER MARKED TRANSMITTER

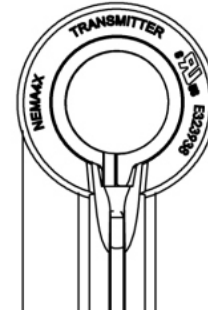

THE SENSORS CAN'T BE REMOVED ONCE THEY ARE INSTALLED. BE SURE THEY ARE IN THE CORRECT ADAPTER.

2)  WIRE THE PHOTOCELLS TO THE CONTROL PANEL. ALL FIELD CONNECTIONS MUST BE SOLDERED TO ENSURE PROPER OPERATION. DO NOT USE OTHER METHODS FOR MAKING FIELD CONNECTIONS.

3) ALIGN THE PHOTOCELLS BY ADJUSTING THEIR ANGLE AND HEIGHT.

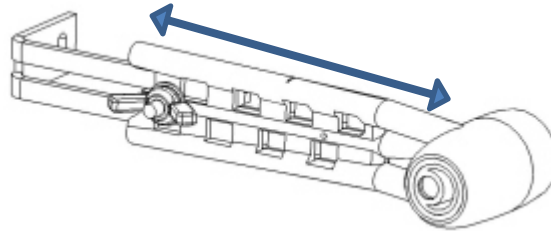
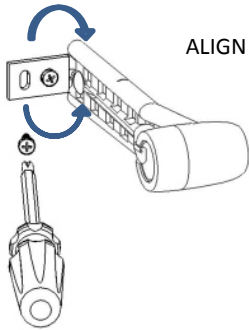

STATUS LED

RED LED (TRANSMITTER)	GREEN LED (RECEIVER)	STATUS
ON	ON	NORMAL OPERATION
OFF	OFF	NO POWER, CHECK WIRING
BLINKS TWICE	ON	BAD ALIGNMENT/OBSTRUCTED BEAM/DEFECTIVE RECEIVER
BLINKS TWICE	OFF	CHECK POWER AND WIRING TO RECEIVER/ DEFECTIVE RECEIVER
BLINKS THREE TIMES	ON	INTERFERENCE FROM AMBIENT LIGHT

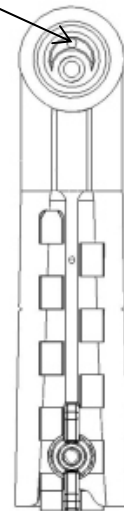

THE MOUNTING LOCATION OF THE PHOTOCELL(S), MOUNTING HEIGHT, DISTANCE FROM THE DOOR, QUANTITY AND WHICH SIDE OF THE DOOR THE PHOTOCELL IS ON, IS TO BE DETERMINED BY THE INSTALLER BASED ON THE TYPE OF TRAFFIC USING THE DOOR, WHICH SIDE OF THE DOOR THE TRAFFIC IS APPROACHING FROM, THE SPEED OF THE TRAFFIC, DOOR SPEED, AND OTHER FACTORS. TNR IS NOT RESPONSIBLE FOR IMPROPER PHOTOCELL PLACEMENT OR WIRING. THE PHOTOCELL SUPPLIED WITH THE DOOR IS INTENDED AS A REVERSING DEVICE.





Ensure that all electrical power sources have been locked out and tagged out according to osha regulations and local electrical codes. Test the equipment to ensure it can't start moving and that all electrical power is disconnected prior to commencing work.



Electrical wiring is to be performed by a qualified electrician and must meet all local, state/provincial., Federal codes.

Ensure that any local disconnects, fuses, or breakers are sized correctly for the product.

The photoswitch supplied with the door is intended for use as a redundant reversing device

(i) The operator and controls are to be wired as per the electrical drawing located inside the control panel.



(ii) Primary power from the control panel to the electric motor must be in a separate electrical conduit from the control wire circuit.



(iii) Using the hand chain move the door to the midposition and with one hand on the stop button test the door movement electrically. If the open and close push buttons have their functions reversed, press the stop button immediately as the door will not stop on the limits. On doors with Feig control panels (printed circuit board) use P. 130 to change the motor rotation (see changing the parameters. On all other control panels swap the position of any two of the motor wires.

Recommended Wiring Requirements From Control Panel to Electric Operator

Revised: May 18, 2017

General

If your control panel was not ordered with the optional fused disconnect, it is recommended (and most likely local code) that the power source be fused immediately prior to entering the panel. Consult your local electrical codes for fusing requirements. When making penetrations in any enclosure, ensure that conduits enter the bottom of the enclosure as penetrations in any other location could void the warranty. Use the appropriate fittings for the application/environment.

Motor Power Conduit

In all cases, Primary Power wires must be an appropriate gauge based on the amperage and length of feed to the electric operator limit box. Consult your local electrical codes. TNR recommends a minimum 14 gauge, multi-strand wire installed in a protective conduit.

Control Wire Conduit

In all cases, Control wires must be an appropriate gauge based on amperage and length of feed to the electric operator limit box. Consult your local electrical codes. TNR recommends a minimum 16 gauge, multi-strand wire installed in a separate protective conduit from the Primary Power wires.

From both conduits, an appropriate flexible conduit should bridge the wires from the wall to the electric operator. In all cases, the reversing edge wires should connect to the coil cord via an electrical junction box located at half the door opening height. Reversing edge wires are not included in the quantities below.

The table below shows how many wires should be pulled in each conduit to wire the operator to the control panel. The door model can be found on the door serial number sticker located on the control panel, operator, and free/spring endplate.

Door Model	Operator	Motor Power	Controls (Relays with contactors)	Controls (PLC with Contactors)	Controls (PLC with Variable Frequency Drive)
HDE	Gearhead (RG)	3 + 1 ground	12 + 2 spares + 1 ground	5 + 2 spares + 1 ground	N/A
HDT	SEW (HG)	3 + 1 ground	15 + 2 spares + 1 ground	8 + 2 spares + 1 ground	N/A
HDS	SEW (HG)	3 + 1 ground	N/A	N/A	9 + 2 spares + 1 ground
HDP	SEW (HG)	3 + 1 ground	N/A	N/A	10 + 2 spares + 1 ground
HDC	SEW (HG)	3 + 1 ground	N/A	N/A	10 + 2 spares + 1 ground
HDC-DD HDL23-DD HDL45-DD HDF, HDEX, HSR	Direct Drive	5 + 1 ground (3 motor, 2 brake)	N/A	N/A	Mechanical Limits (6 + 2 spares + 1 ground) Encoder Limits (Use supplied shielded cable)
Chillfast	Direct Drive	Plug n Play	N/A	N/A	Plug n Play
HDL23 & HDL45	SEW (HG)	3 + 1 ground	15 + 2 spares + 1 ground	8 + 2 spares + 1 ground	N/A
HDXL 6, 7, 8, 9 A, 9B, & 9C	SEW (HG)	3 + 1 ground	15 + 2 spares + 1 ground	8 + 2 spares + 1 ground	N/A



DO NOT COIL AND ZIP TIE OR ATTACH THE ENCODER CABLE IN ANY MANNER TO THE HIGH VOLTAGE EMT OR FLEXIBLE CONDUIT TO AVOID INTERFERENCE AND UNWANTED OPERATION OF THE DOOR.

SEE ELECTRICAL SCHEMATIC FOR CIRCUIT WIRING

Determining breaker and wire size
Dimensions in parenthesis are in millimeters

SM-0315
Rev. D

	Primary voltage from building								
	Poles			Minimum breaker size (amps)			Maximum motor current (amps)		
Door Model	208V-240V	460V-480V	575V-600V	208V-240V	460V-480V	575V-600V	208V-240V	460V-480V	575V-600V
HDE	3	3	3	15	10	10	6.2	3.1	2.5
HDT, HDL23, HDL45	3	3	3	15	10	10	5.7	2.85	2.3
HDS, HDC, HDP, HDLH	1 if L / N 2 if L / L	3	1 if L / N 2 if L / L	15	10	10	8	4	8
HDC-DD, HDL23-DD, HDL45-DD	3	3	3	20	20	20	12.4	12.4	12.4
HDFX, HSR	3	3	3	20	15	20	11.5	6	11.5
HDXL6, HDXL9	3	3	3	15	10	10	8	4	3.2
HDF	1 if L / N 2 if L / L	1 if L / N 2 if L / L	1 if L / N 2 if L / L	10	10	10	5.3	5.3	5.3
Chillfast	3	3	3	10	10	10	5.3	5.3	5.3

- The above chart is for the highest current for each door model and voltage. The current varies with door Size, model and motor voltage. The motor voltage may not be the same as the building primary. For a Specific door's current draw contact TNR field service at 705-792-9968.
- Each door should have a dedicated circuit breaker. There should be no more than one door per breaker.
- The distance from the breaker and control panel as well as the panel and operator will affect the size of The wire required. See below to properly size motor and primary wires.

To find the correct wire size you must first determine the required circular mils (cm) with the formula below.

$$CM = \frac{19.3984 \times \text{Maximum motor current (See above chart)} \times \text{One way distance in feet from breaker to motor}}{\text{Allowable voltage drop (see chart below)}}$$

Allowable voltage drop based on building primary		
208V-240V	460V-480V	575V-600V
6	14	17

Using the answer from the above formula look up the circular mils in the table below. If the calculated Circular mils isn't the exact same as in the chart use the next largest circular mils in the chart below. TNR Recommends a minimum 14awg wire for the building primary and motor.

Wire Gauge (AWG)	Circular Mils (CM)
0000	211592
000	167800
00	133072
0	105531
1	83690
2	66369

Wire Gauge (AWG)	Circular Mils (CM)
3	52633
4	41740
5	33101
6	26251
7	20818
8	16509

Wire Gauge (AWG)	Circular Mils (CM)
9	13092
10	10383
11	8234
12	6530
13	5178
14	4107

**RECOMMENDED CONDUIT LAYOUT
DIMENSIONS IN PARENTHESES ARE IN MILLIMETERS**

THIS DRAWING IS INTENDED AS A GUIDE ONLY. CONSULT LOCAL, STATE/PROVINCIAL, AND FEDERAL ELECTRICAL CODES.

SOME ELECTRICAL OPTIONS MAY REQUIRE ADDITIONAL WIRING. REFER TO THE AS BUILT ELECTRICAL DRAWING SUPPLIED WITH THE DOOR.

ALL WIRING SHOULD BE PERFORMED BY A QUALIFIED ELECTRICIAN.

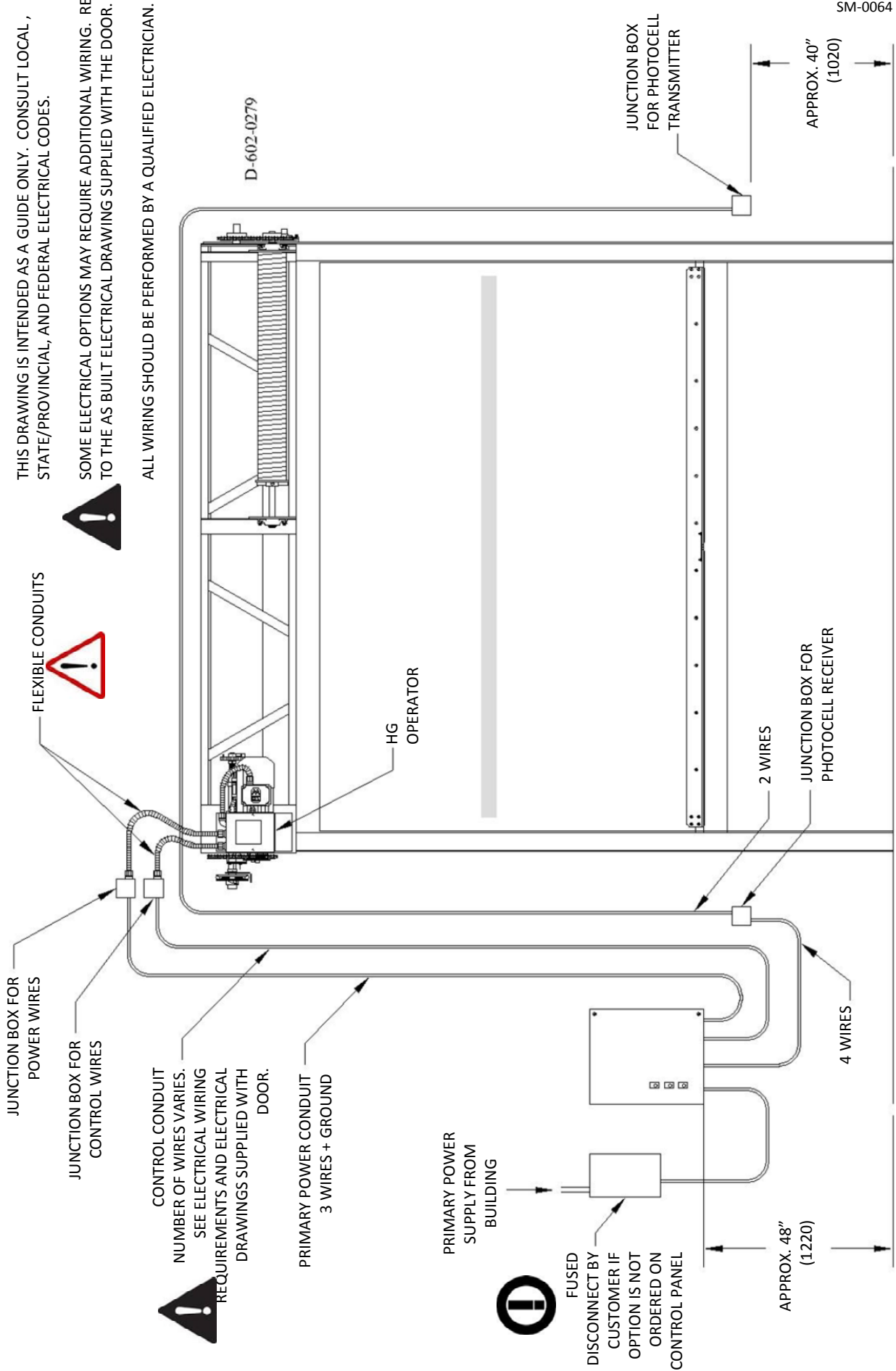

D-602-0279

**RECOMMENDED CONDUIT LAYOUT
DIMENSIONS IN PARENTHESES ARE IN MILLIMETERS**

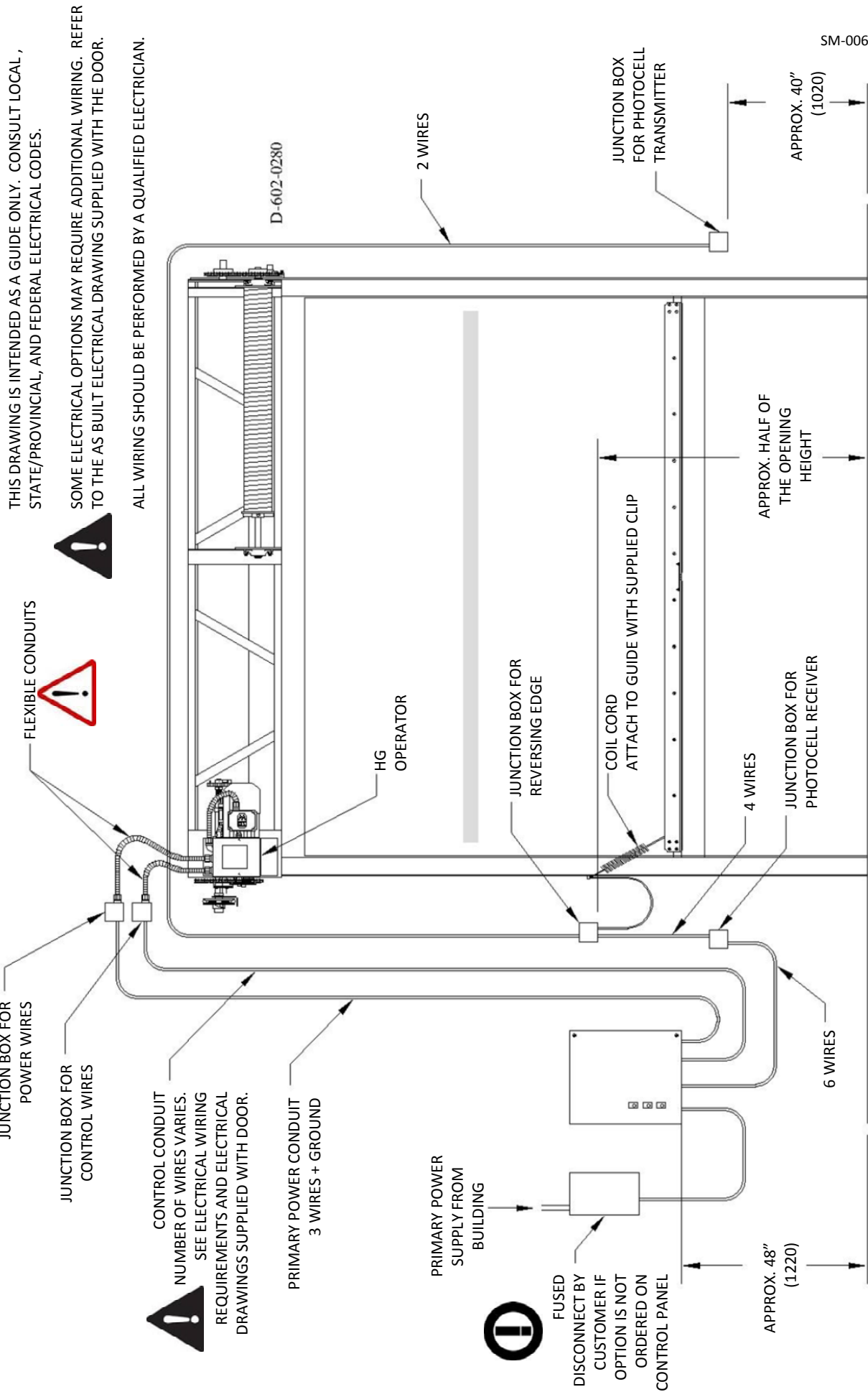

THIS DRAWING IS INTENDED AS A GUIDE ONLY. CONSULT LOCAL, STATE/PROVINCIAL, AND FEDERAL ELECTRICAL CODES.

SOME ELECTRICAL OPTIONS MAY REQUIRE ADDITIONAL WIRING. REFER TO THE AS BUILT ELECTRICAL DRAWING SUPPLIED WITH THE DOOR.

ALL WIRING SHOULD BE PERFORMED BY A QUALIFIED ELECTRICIAN.



FLEXIBLE CONDUITS



! CONTROL CONDUIT NUMBER OF WIRES VARIES. SEE ELECTRICAL WIRING REQUIREMENTS AND ELECTRICAL DRAWINGS SUPPLIED WITH DOOR.

PRIMARY POWER CONDUIT 3 WIRES + GROUND

PRIMARY POWER SUPPLY FROM BUILDING



FUSED BY CUSTOMER IF OPTION IS NOT ORDERED ON CONTROL PANEL

APPROX. 48" (1220)

APPROX. 40" (1020)

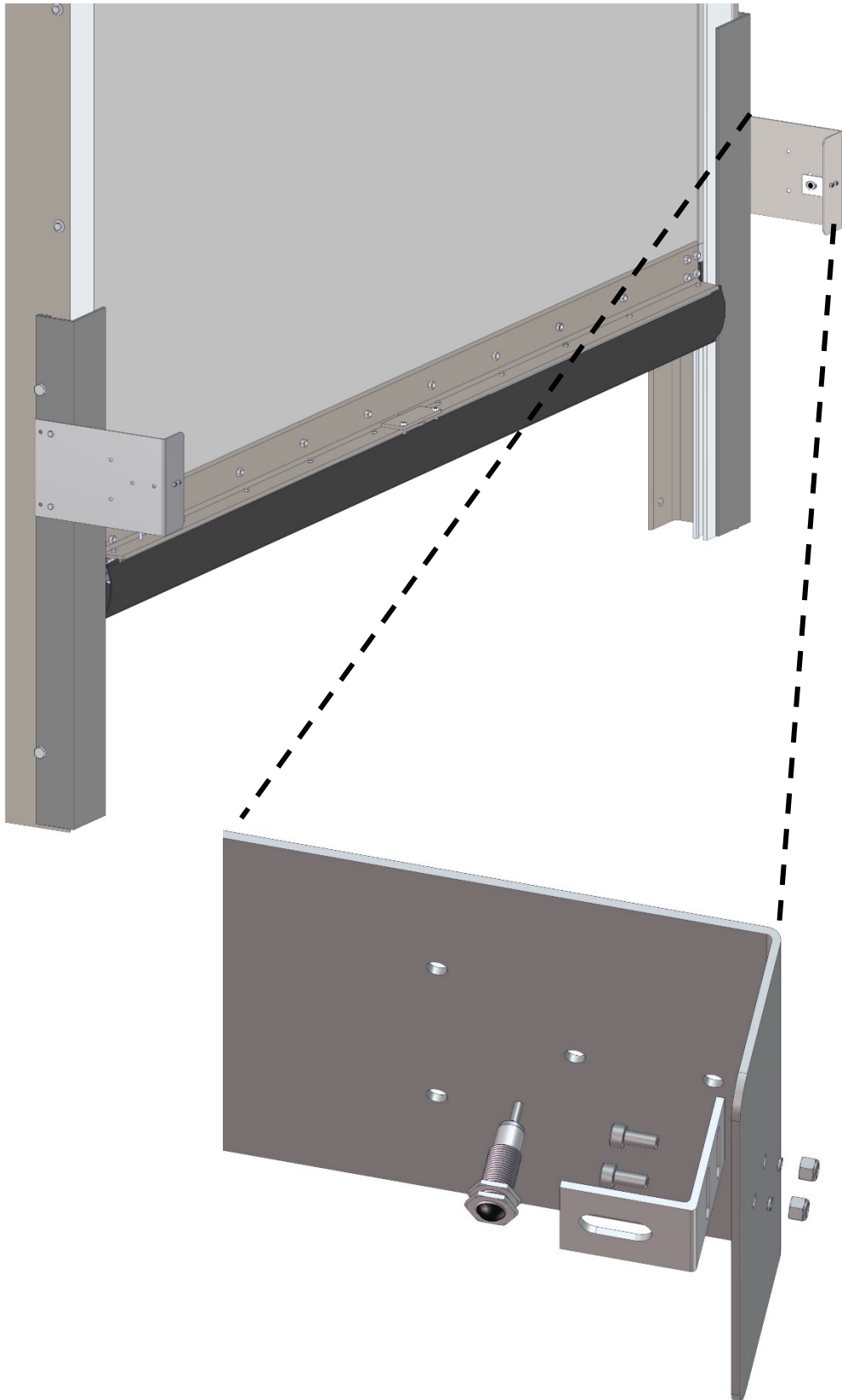

Telco photocell wiring instructions – Non monitored

SM-0441
Rev. REL

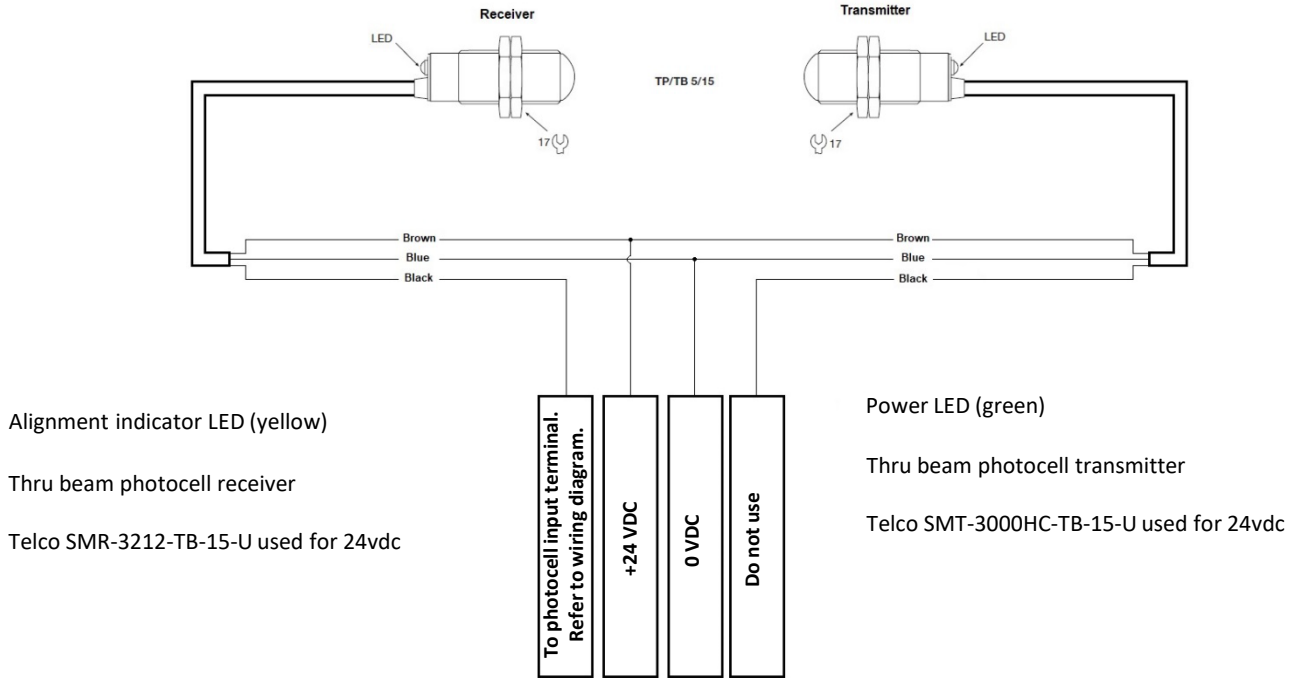

Telco photocell wiring instructions – Monitored

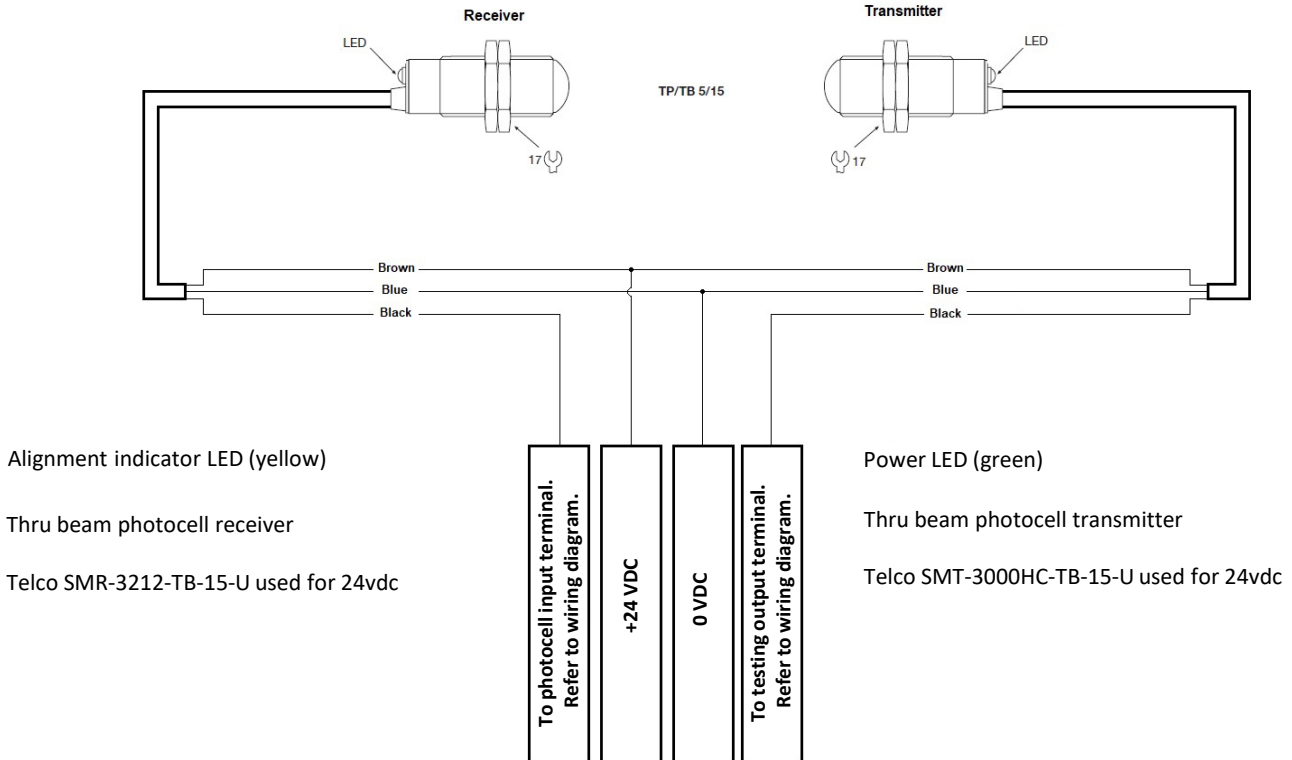

Control panel or Operator mounted controls terminal strip
Refer to electrical drawings supplied with door for terminal numbers

INSTALL AIR WAVE REVERSING EDGE SWITCH
DIMENSIONS IN PARENTHESIS ARE IN MILLIMETERS

SM-0077

AIR WAVE COIL CORD



(i) ATTACH THE AIR HOSE FROM THE BOTTOM BAR TO THE BRASS FITTING ON THE EXTERIOR OF THE BOX.

(ii) ATTACH THE SWITCH TO THE BOTTOM BAR USING THE HARDWARE PROVIDED.



(iii) ATTACH THE COIL CORD TO THE BOTTOM BAR USING THE CLIP AND HARDWARE PROVIDED. ENSURE THE AIR HOSE HAS NO KINKS IN IT. CHECK BETWEEN THE REVERSING EDGE AND THE BOTTOM BAR INSIDE THE LOOP SEAL.

AIR WAVE WIRELESS

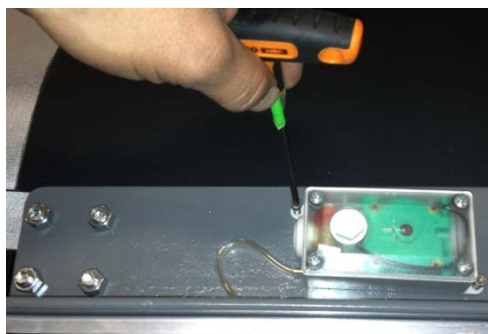

(i) ATTACH THE AIR HOSE FROM THE BOTTOM BAR TO THE BRASS FITTING ON THE EXTERIOR OF THE BOX.

(ii) ATTACH THE SWITCH TO THE BOTTOM BAR USING THE HARDWARE PROVIDED

(iii) FOLLOW THE INSTRUCTIONS IN THIS MANUAL TO PROGRAM THE WIRELESS EDGE



ENSURE THE AIR HOSE HAS NO KINKS IN IT. CHECK BETWEEN THE REVERSING EDGE AND THE BOTTOM BAR INSIDE THE LOOP SEAL.

ADJUSTING THE AIR WAVE SWITCH
DIMENSIONS IN PARENTHESIS ARE IN MILLIMETERS

SM-0078



TURN THE POWER OFF AND LOCK OUT THE DOOR PRIOR TO COMMENCING WORK. THE DOOR **WILL** MOVE UNEXPECTEDLY WHILE ADJUSTING THE SWITCH IF NOT LOCKED OUT.

WIRELESS

- (i) REMOVE THE PAPER FROM THE BATTERY IF NOT ALREADY DONE.
- (ii) TURN THE BLACK ADJUSTING SCREW COUNTER CLOCKWISE TWO FULL TURNS.
- (iii) SLOWLY TURN THE BLACK ADJUSTING SCREW CLOCKWISE UNTIL THE GREEN INDICATOR LIGHT ON THE CIRCUIT BOARD COMES ON.
- (iv) TURN THE BLACK ADJUSTING SCREW COUNTERCLOCKWISE 1/4 OF A TURN

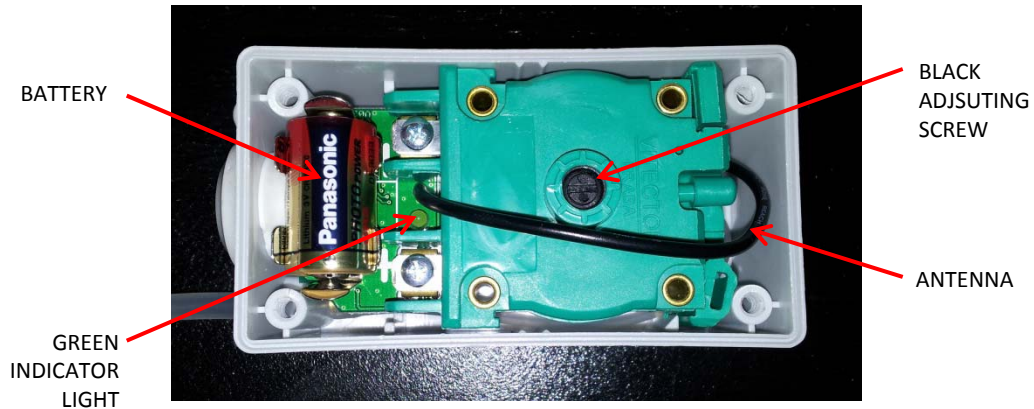

COIL CORD – NORMALLY CLOSED CONTACT (NCC) – REFER TO YOUR SCHEMATIC TO DETERMINE WHICH TYPE YOUR CONTROLS USE

- (i) USING AN OHM METER ON THE TERMINALS, SLOWLY TURN THE BLACK ADJUSTING SCREW COUNTER CLOCKWISE UNTIL THE OHM METER INDICATES THE SWITCH IS OPEN (NO CONTINUITY).
- (ii) USING AN OHM METER ON THE TERMINALS, SLOWLY TURN THE BLACK ADJUSTING SCREW CLOCKWISE UNTIL THE OHM METER INDICATES THE SWITCH IS CLOSED (CONTINUITY).
- (iii) TURN THE BLACK ADJUSTING SCREW CLOCKWISE ANOTHER 1/4 OF A TURN.
- (vi) CONFIRM THE SWITCH IS CLOSED (CONTINUITY) WITH THE OHM METER.

COIL CORD – NORMALLY OPEN CONTACT (NOC) – REFER TO YOU SCHEMATIC TO DETERMINE WHICH TYPE YOUR CONTROLS USE

- (i) USING AN OHM METER ON THE TERMINALS, SLOWLY TURN THE BLACK ADJUSTING SCREW CLOCKWISE UNTIL THE OHM METER INDICATES THE SWITCH IS CLOSED (CONTINUITY).
- (ii) USING AN OHM METER ON THE TERMINALS, SLOWLY TURN THE BLACK ADJUSTING SCREW COUNTER CLOCKWISE UNTIL THE OHM METER INDICATES THE SWITCH IS OPEN (NO CONTINUITY).
- (iii) TURN THE BLACK ADJUSTING SCREW COUNTER CLOCKWISE ANOTHER 1/4 OF A TURN.
- (iv) CONFIRM THE SWITCH IS OPEN (NO CONTINUITY) WITH THE OHM METER.

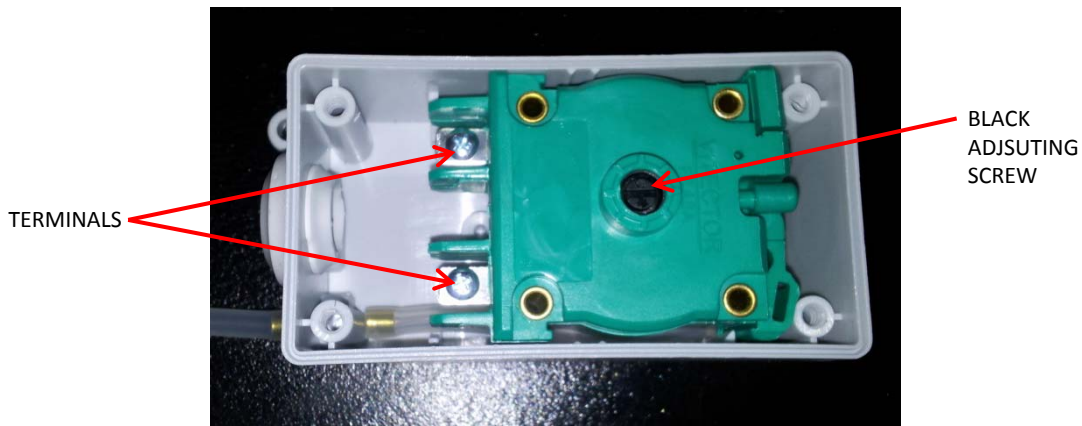

TRANSMITTER

SHIPPED LOOSE TO BE INSTALLED AFTER THE DOOR IS INSTALLED

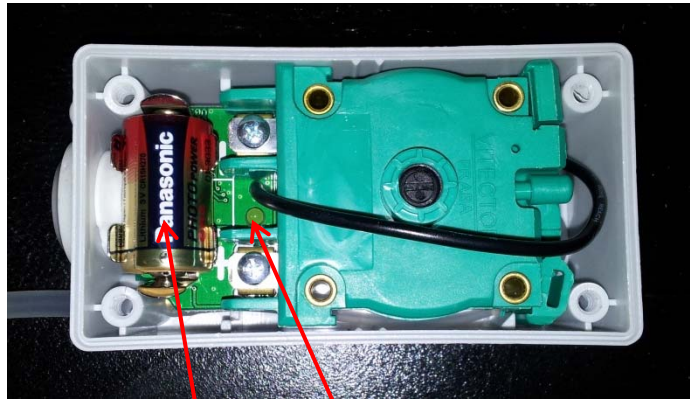

BATTERY (REMOVE PAPER INSERT)
 TRANSMITTER LED

RECEIVER

THE RECEIVER WILL BE FACTORY INSTALLED AND WIRED IN THE CONTROL PANEL

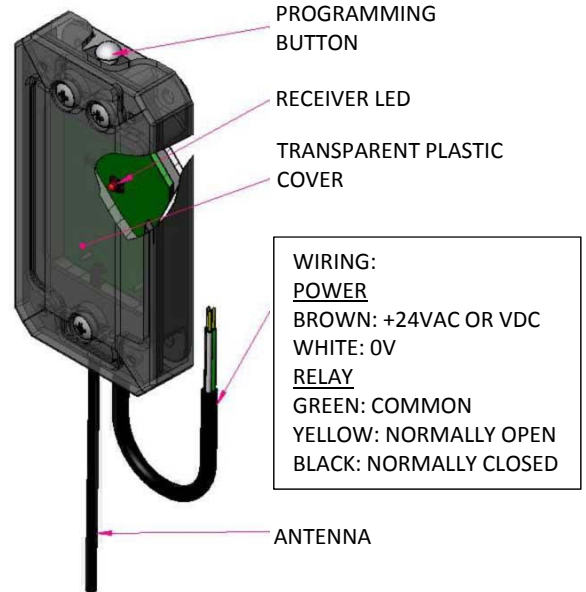

WIRING:
POWER
 BROWN: +24VAC OR VDC
 WHITE: 0V
RELAY
 GREEN: COMMON
 YELLOW: NORMALLY OPEN
 BLACK: NORMALLY CLOSED

Programming

- 1) MOVE THE DOOR SO THAT THE BOTTOM BAR IS APPROX. 48" FROM THE FLOOR AND PRESS THE E-STOP ON THE CONTROL PANEL
- 2) REMOVE THE LID FROM THE TRANSMITTER
- 3) REMOVE THE PAPER FROM THE BATTERY IN THE TRANSMITTER
- 4) PRESS AND HOLD THE PROGRAMMING BUTTON ON THE RECEIVER UNTIL THE RECEIVER LED BEGINS FLASHING SLOWLY. **ONCE IT BEGINS FLASHING RELEASE THE PROGRAMMING BUTTON**
- 5) ACTIVATE THE REVERSING EDGE WITH YOUR HAND (THE TRANSMITTER LED WILL COME ON ONCE. THE RECEIVER LED WILL FLASH QUICKLY 8 TIMES THEN STOP).
- 6) THE RECEIVER LED WILL BEGIN FLASHING SLOWY AGAIN. WHEN IT DOES PRESS AND HOLD THE PROGRAMMING BUTTON UNTIL THE RECEIVER LED FLASHES QUICKLY. **REMOVE YOUR FINGER FROM THE PROGRAMMING BUTTON BEFORE THE RECEIVER LED STOPS FLASHING.**
- 7) THE RECEIVER LED WILL NOW BE OFF. IF IT IS STILL ON THAT MEANS THE PROGRAMMING BUTTON WAS NOT RELEASED PRIOR TO THE RECEIVER LED FINISHED FLASHING. RETURN TO STEP 4.
- 8) ACTIVATE THE REVERSING EDGE WITH YOUR HAND WHILE THE DOOR IS CLOSING. THE TRANSMITTER AND RECEIVER LED'S SHOULD BOTH COME ON ONCE AND THE DOOR SHOULD REVERSE.

RECEIVER LED	
OFF	IDLE - WAITING FOR SIGNAL FROM TRANSMITTER TO REVERSE DOOR
SLOW FLASHING DURING PROGRAMMING	WAITING FOR SIGNAL FROM TRANSMITTER TO SYNC TRANSMITTER AND RECEIVER
QUICK FLASHING DURING PROGRAMMING	RELAY IN RECEIVER IS BEING PROGRAMMED
FLASHES ONCE DURING NORMAL OPERATION	RECEIVED A SIGNAL FROM THE TRANSMITTER TO REVERSE THE DOOR
SLOW FLASHING DURING NORMAL OPERATION	BATTERY IS LOW – CHANGE THE BATTERY

TRANSMITTER LED	
OFF	IDLE - WAITING FOR ACTIVATION OF REVERSING EDGE
FLASHES ONCE	RECEIVED AN ACTIVATION FROM THE REVERSING EDGE. SENDING A SIGNAL TO THE RECEIVER
FLASHES TWICE OR THREE TIMES	RECEIVED AN ACTIVATION FROM THE REVERSING EDGE. SENDING A SIGNAL TO THE RECEIVER BUT WITH REDUCED BATTERY POWER. REPLACE BATTERY.

Transmitter

Shipped loose to be installed after the door is installed

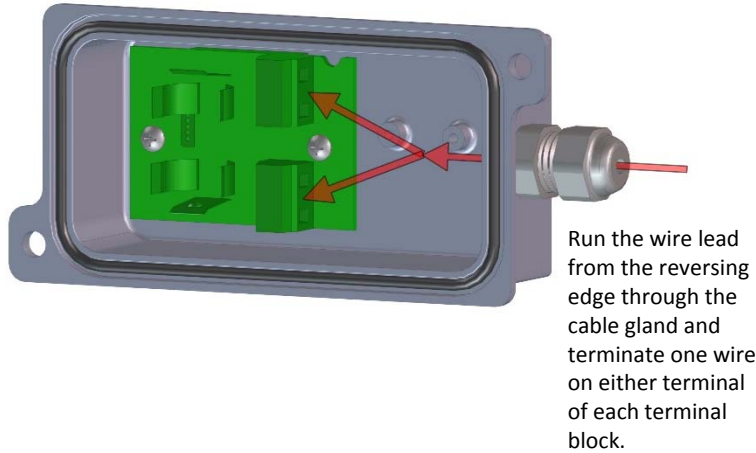

Receiver

The receiver will be factory installed and wired in the control panel

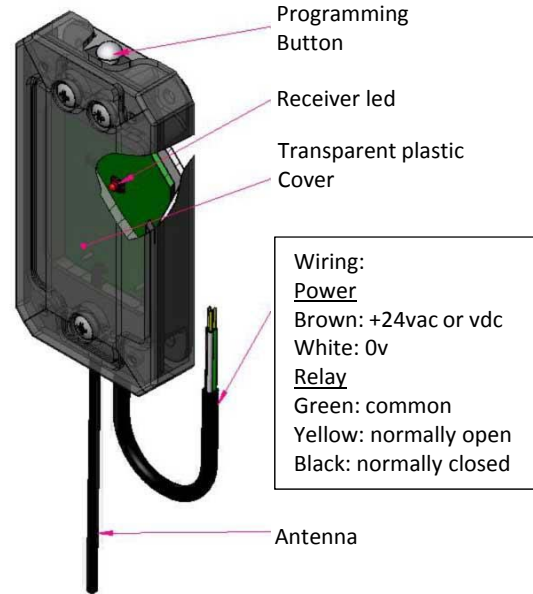

Programming

- 1) Move the door so that the bottom bar is approx. 48" from the floor and press the e-stop on the control panel
- 2) Remove the lid from the transmitter
- 3) Remove the paper from the battery in the transmitter
- 4) Press and hold the programming button on the receiver until the receiver led begins flashing slowly. **Once it begins flashing release the programming button**
- 5) Activate the reversing edge with your hand (the transmitter led will come on once. The receiver led will flash quickly 8 times then stop).
- 6) The receiver led will begin flashing slow again. When it does press and hold the programming button until the receiver led flashes quickly. **Remove your finger from the programming button before the receiver led stops flashing.**
- 7) The receiver led will now be off. If it is still on that means the programming button was not released prior to the receiver led finished flashing. Return to step 4.
- 8) Activate the reversing edge with your hand while the door is closing. The transmitter and receiver led's should both come on once and the door should reverse.

Receiver led	
Off	Idle - waiting for signal from transmitter to reverse door
Slow flashing during programming	Waiting for signal from transmitter to sync transmitter and receiver
Quick flashing during programming	Relay in receiver is being programmed
Flashes once during normal operation	Received a signal from the transmitter to reverse the door
Slow flashing during normal operation	Battery is low – change the battery

Transmitter led	
Off	Idle - waiting for activation of reversing edge
Flashes once	Received an activation from the reversing edge. Sending a signal to the receiver
Flashes twice or three times	Received an activation from the reversing edge. Sending a signal to the receiver but with reduced battery power. Replace battery.

Installing monitored edge transmitter

Dimensions in parenthesis are in millimeters

SM-0382
Rev. REL.

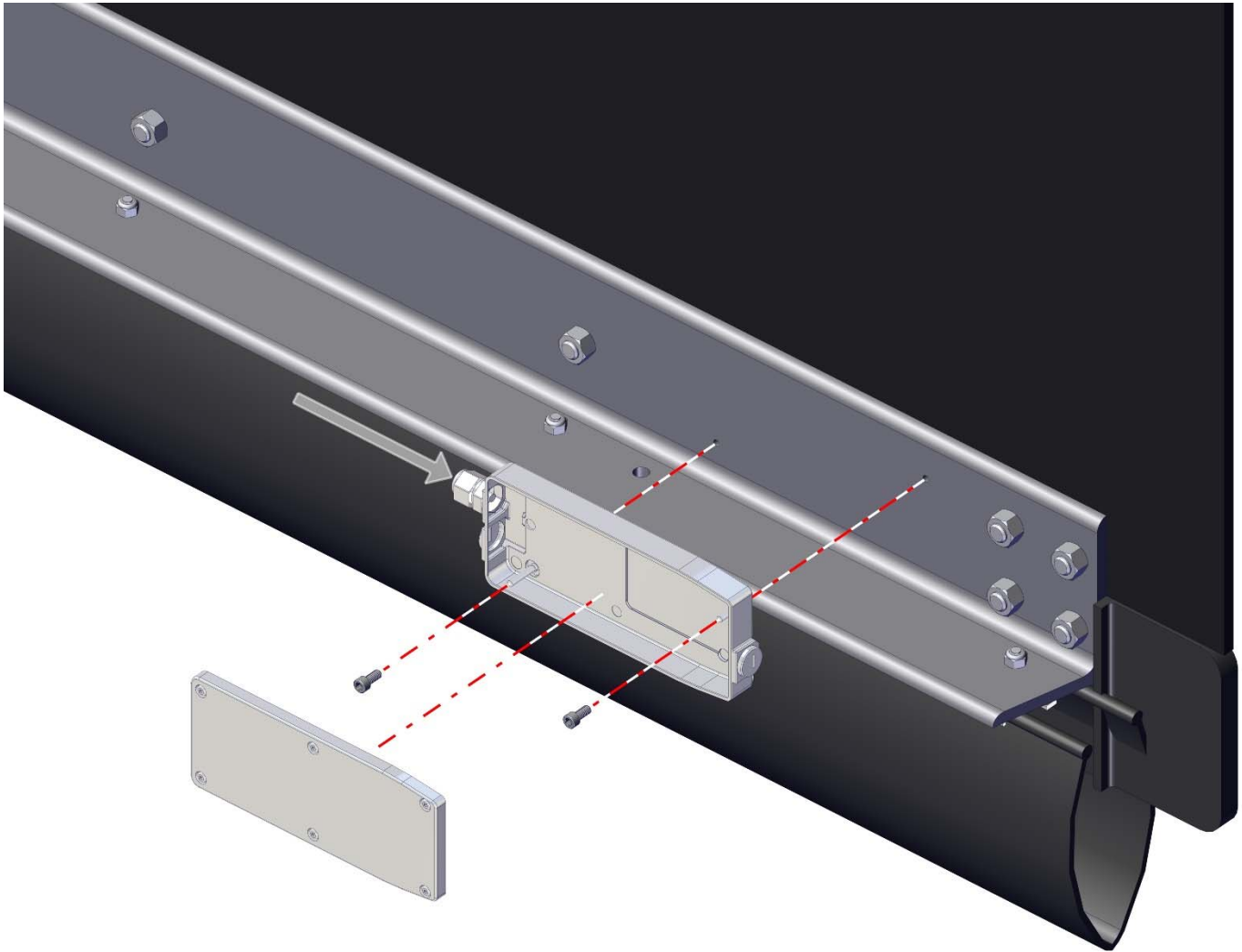

Using the kit label *Monitored Edge Transmitter* install the monitored wireless edge transmitter by removing the lid and bolting it to the bottom bar with the supplied screws.

Pass the reversing edge wires through the cable gland highlighted by the arrow above.

Do not reinstall lid until the after the edge wires are connected and the transmitter and receiver are programmed. See *Programming Monitored Edge* on the following pages of this manual.

Install monitored wireless edge receiver

Dimensions in parenthesis are in millimeters

SM-0386
Rev. REL.

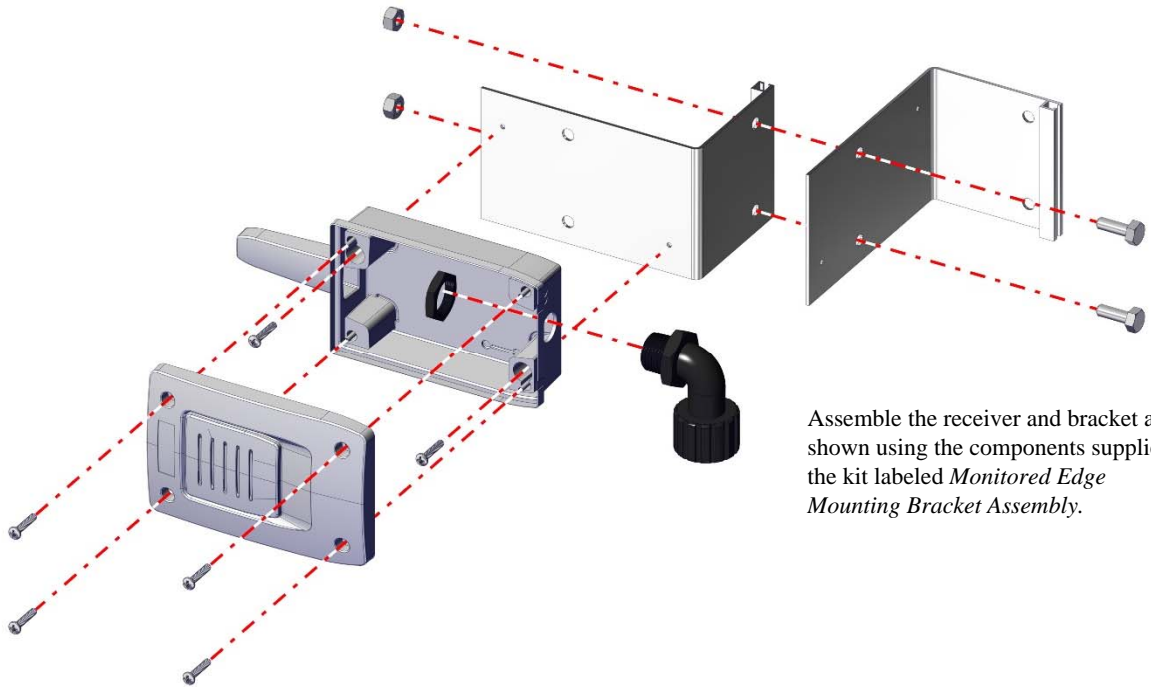

Assemble the receiver and bracket as shown using the components supplied in the kit labeled *Monitored Edge Mounting Bracket Assembly*.

Mount the receiver and bracket assembly at approximately half the door height on the same side of the door as the door control panel.

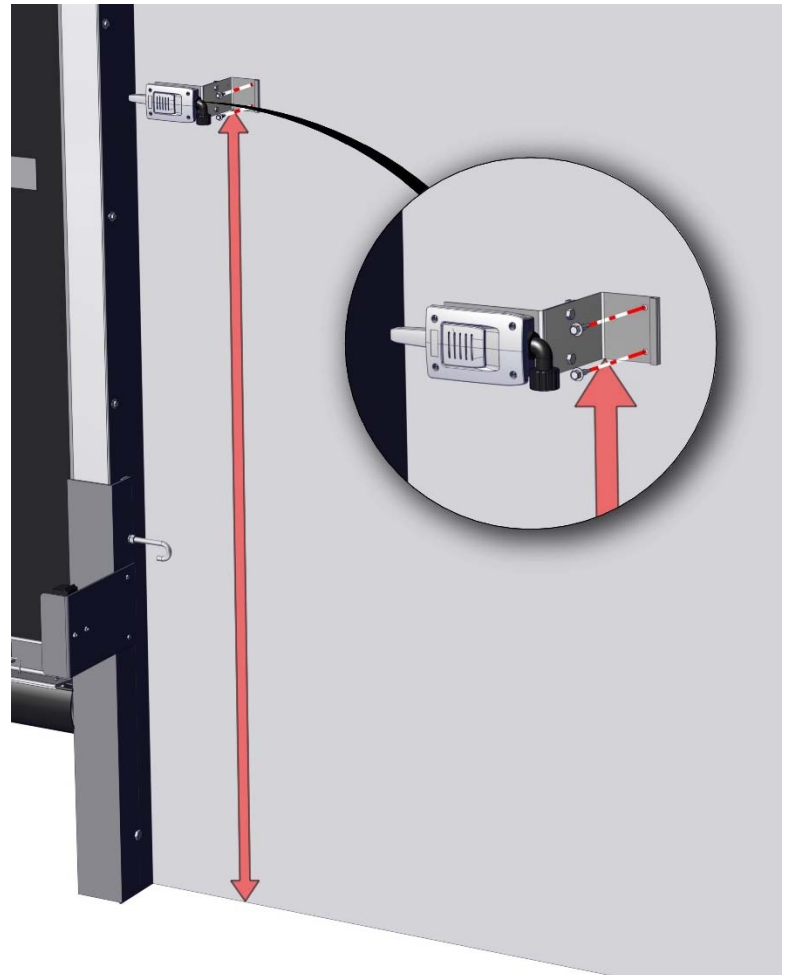

Set up the transmitter

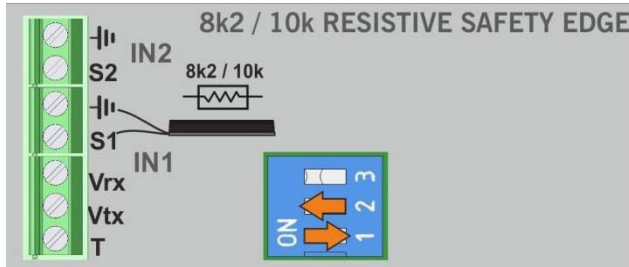

Wire the reversing edge to transmitter terminals S1 and \perp .
 Set transmitter DIP switch 1 to *OFF*.
 Set transmitter DIP switch 2 to *ON*.
 Transmitter DIP switch 3 is not used.
 Plug in the battery connector to the circuit board.

Set up the receiver

Check (test) button and LED

Relay LED's. Only R1 is used

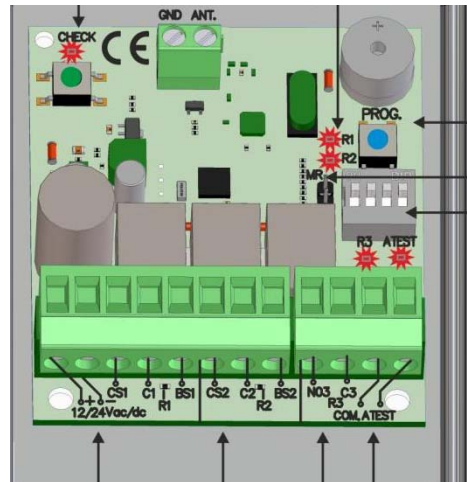

Receiver programming button
 MR jumper (for reset procedure)
 DIP switches

Relay 1 and 24VDC connections
 Relay 2 connections (Not used)
 ATEST connections (Not used)

Logic Board Controls

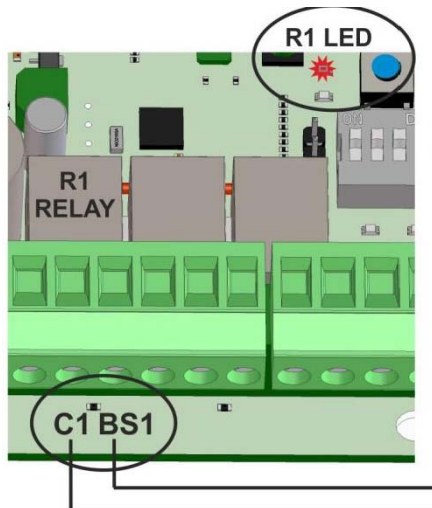

The receiver will use relay R1 only.
 Wire the relay using terminals shown for your type of controls.
 Use the + and - terminals for 24VDC power.
 See the wiring diagram supplied with the door for the panel connections.

Note the position of R1 LED

Set receiver DIP switch 1 to *OFF*.
 Receiver DIP switch 2 is not used
 Set receiver DIP switch 3 to *OFF*.
 Set receiver DIP switch 4 to *OFF*.

PLC or Relay Controls

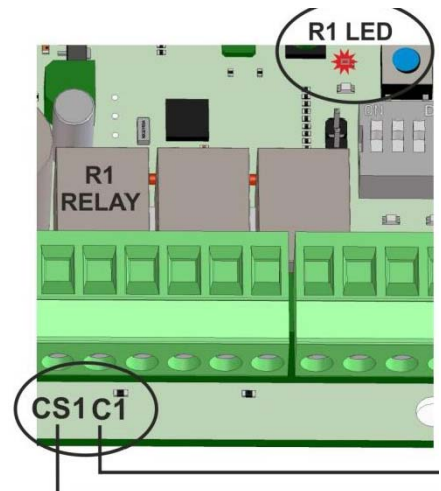

Programming sequence

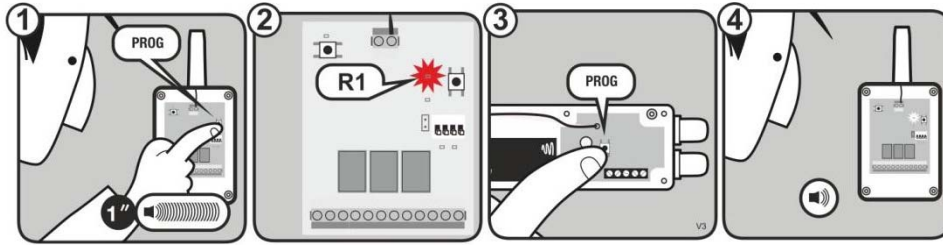

- 1) Press the programming (PROG) button until the R1 LED comes on. If it comes on and then off again because you held the button too long keep pressing the PROG button as it will cycle through the other options and come back to R1.
- 2) The R1 LED will remain illuminated.
- 3) Press the programming (PROG) button on the transmitter.
- 4) You will hear a beep on the receiver if the programming sequence was successful.
- 5) Reinstall the lid to the transmitter

Reset sequence

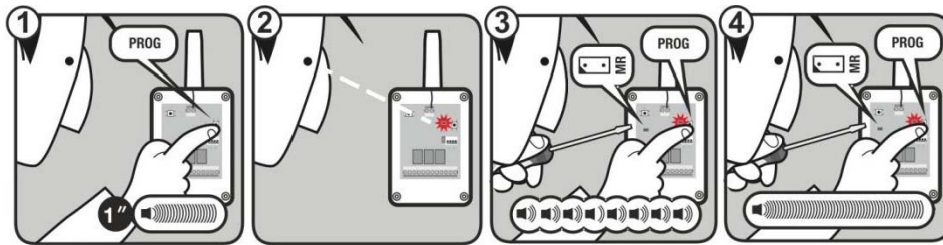

- 1) Press and hold the programming (PROG) button until the R1 LED comes on. Do not let go of the PROG button.
- 2) The R1 LED will remain illuminated.
- 3) Using a small screw driver bridge the pins at jumper MR.
- 4) You will hear 10 beeps on the receiver followed by a series of faster beeps if the programming sequence was successful.

Receiver and transmitter LED's

Receiver			Transmitter		
RB3 R			RB3 T		
R1/R2 LED	ATEST LED	BEEPS	IN1/IN2 LED		
*	*	⊗	*		Edge activated
			*		Receiver is being activated by another transmitter
			***		The edge is not connect, the transmitter receiver is not programmed, or the DIP switches are incorrect
		4x / 5s	*		Low battery or loss of communication
	*	⊗	*		Receiver is in the wrong mode and waiting for a test signal
*	*	⊗	*		Signal is being disrupted
---	---	1x	---		Receiver memory is full
---	---	4x	---		
---	---	7x	---		Change in operating mode of receiver with current programmed transmitters

PLC STATUS MESSAGES
DIMENSIONS IN PARENTHESIS ARE IN MILLIMETERS
(PLC CONTROL PANELS ONLY)

SM-0172
 Rev. REL.

MESSAGE	DISPLAYED WHEN	POSSIBLE FAULTS
DOOR IS FULL OPEN	DOOR IS ON THE OPEN LIMIT	<ul style="list-style-type: none"> - N.C. LIMIT CIRCUIT IS OPEN - FAULTY LIMIT SWITCH - SWITCH IS ACTIVATED
DOOR IS FULL CLOSED	DOOR IS ON THE CLOSE LIMIT	<ul style="list-style-type: none"> - N.C. LIMIT CIRCUIT IS OPEN - FAULTY LIMIT SWITCH - SWITCH IS ACTIVATED
PHOTOEYE ACTIVATED	PHOTOEYE IS ACTIVATED	<ul style="list-style-type: none"> - N.C. PHOTOEYE CIRCUIT IS OPEN - PHOTOEYE ARE MISALIGNED - PHOTOEYE NOT POWERED - PHOTOEYE IS DEFECTIVE
S. EDGE ACTIVATED	REVERSING EDGE IS ACTIVATED	<ul style="list-style-type: none"> - N.C. REVERSING EDGE CIRCUIT IS OPEN - REVERSING EDGE IS ADJUSTED IMPROPERLY - WIRELESS EDGE NOT PROGRAMMED OR BATTERY IS DEAD - REVERSING EDGE/SWITCH IS DEFECTIVE
CHAIN HOIST/SAFETY LIMITS ACTIVATED	<ul style="list-style-type: none"> - THE CHAIN HOIST IS ENGAGED - SAFETY LIMITS ARE ENGAGED (S1 AND S2 LIMIT SWITCHES – DIRECT DRIVE MODELS ONLY) 	<ul style="list-style-type: none"> - CHAIN HOIST INTERLOCK CIRCUIT IS OPEN - CHAIN HOIST DIDN'T RETURN PROPERLY TO ACTIVATE SWITCH - CHAIN HOIST INTERLOCK SWITCH IS DEFECTIVE - N.C. SAFETY LIMIT CIRCUIT IS OPEN (DIRECT DRIVE MODELS ONLY)
TC COUNTING	THE TIMER TO CLOSE IS COUNTING DOWN	<ul style="list-style-type: none"> - TIMER IS SET TOO HIGH. SEE SCHEMATIC FOR INSTRUCTIONS TO SET TIMER
DOOR IS OPENING	THE DOOR IS OPENING	<ul style="list-style-type: none"> - PLC IS OUTPUTTING A SIGNAL TO OPEN THE DOOR BUT DOOR DOESN'T MOVE
DOOR IS CLOSING	THE DOOR IS CLOSING	<ul style="list-style-type: none"> - PLC IS OUTPUTTING A SIGNAL TO CLOSE THE DOOR BUT DOOR DOESN'T MOVE
IN. BRAKE ACTIVATED	THE INERTIA BRAKE INTERLOCK SWITCH IS TRIPPED	<ul style="list-style-type: none"> - THE INERTIA BRAKE INTERLOCK SWITCH CIRCUIT IS OPEN - THE INERTIA BRAKE HAS LOCKED UP CAUSING THE INTERLOCK SWITCH TO TRIP
OVERLOAD ACTIVATED	THE THERMAL OVERLOAD HAS TRIPPED	<ul style="list-style-type: none"> - RESET THE THERMAL OVERLOAD (CONTACTOR PANELS) - PRESS STOP/RESET (VFD PANELS ONLY)
INPUT/OUTPUT STATUS SCREEN (SHOWS INPUTS, OUTPUTS, RUN FBD, DATE AND TIME)	PUSH/PULL E-STOP IS PRESSED	<ul style="list-style-type: none"> - N.C. STOP CIRCUIT IS OPEN. CHECK ALL STOP BUTTONS ON THE CIRCUIT.

ELECTRICAL TROUBLESHOOTING GUIDE

SM-0095

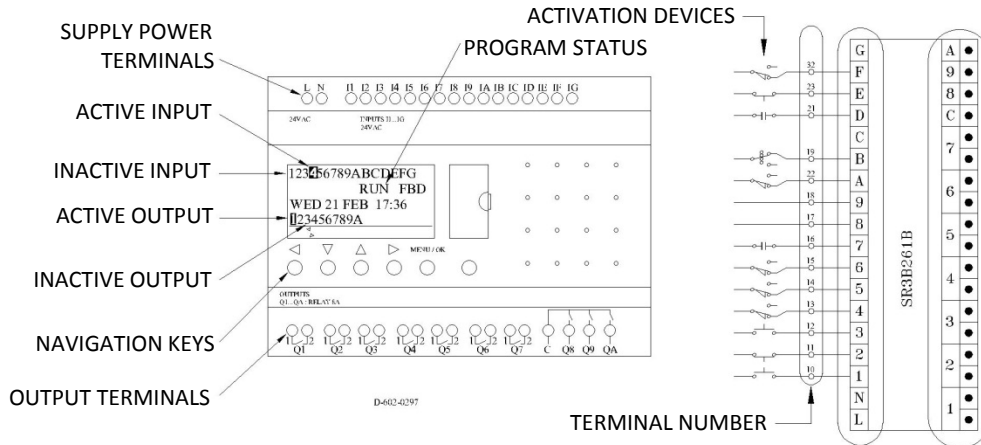

REFER TO NOTES (i), (ii), AND DIAGRAMS FOR HOW TO READ PLC INPUT/OUTPUT ACTIVATION		
SYMPTOM	POSSIBLE CAUSE	SOLUTION
DOOR DOES NOT OPERATE ELECTRICALLY	<ul style="list-style-type: none"> - MANUAL CHAIN HOIST DISCONNECT SWITCH ENGAGED - BLOWN FUSE - DISCONNECT TURNED OFF - MOTOR OVER LOAD TRIPPED - PLC PROGRAM STOPPED 	<ul style="list-style-type: none"> - DISENGAGE CHAIN HOIST / ADJUST CABLE TENSION - REPLACE FUSES - TURN DISCONNECT ON - RESET OVER LOAD - CHECK PROGRAM STATUS ON DISPLAY. RESTART PROGRAM
RUNS IN OPPOSITE DIRECTION	<ul style="list-style-type: none"> - PHASING IS REVERSED 	<ul style="list-style-type: none"> - INTERCHANGE M1 & M2 FIELD WIRES
DOOR REVERSES WHEN CLOSING	<ul style="list-style-type: none"> - PHOTCELLS MISALIGNED - REVERSING EDGE / PHOTCELL / FLOOR LOOP SENSITIVITY SET TOO HIGH - SHORT CIRCUIT IN SAFETY DEVICE WIRING - COIL CORD TRIPS PHOTOCELL 	<ul style="list-style-type: none"> - ADJUST PHOTOCELLS SO THAT ALL THREE LIGHTS ARE LIT ON TOP OF PHOTOCELL RECEIVER - ADJUST DEVICE SENSITIVITY - TRACE WIRING TO FIND SHORT CIRCUIT - ADJUST COIL CORD / PHOTOCELL POSITION
REVERSING EDGE DOES NOT REVERSE DOOR	<ul style="list-style-type: none"> - KINKED SENSING TUBE - SENSITIVITY SET TOO LOW - FAULTY REVERSING EDGE - WIRED INCORRECTLY 	<ul style="list-style-type: none"> - DISCONNECT POWER, THEN DISCONNECT THE SENSING TUBE FROM THE AIR SWITCH AND HOLD THE END OF THE TUBE UP TO YOUR EAR AND HIT THE REVERSING EDGE WITH YOUR HAND. IF YOU CAN'T FEEL AND HEAR THE AIR COMING FROM THE EDGE, TRY TO CLEAR THE SENSING TUBE. IF PROBLEM PERSISTS REPLACE THE SENSING TUBE. - ADJUST SENSITIVITY - CONTINUITY TEST REVERSING EDGE AND REPLACE IF NECESSARY - VERIFY WIRING.
PHOTOCELL DOES NOT REVERSE DOOR	<ul style="list-style-type: none"> - SENSITIVITY SET TOO LOW - WIRED INCORRECTLY - FAULTY PHOTOCELL 	<ul style="list-style-type: none"> - CHECK THE TOP OF THE LIGHT SOURCE AND RECEIVER TO ENSURE ALL OF THE LIGHTS ARE LIT UP. PLACE SOMETHING OVER ONE OF THE PHOTOCELLS TO BLOCK THE BEAM AND CHECK THE PLC TO SEE THAT THE PHOTOCELL IS ACTIVATED. REFER TO PHOTOCELL WIRING DIAGRAM FOR PROPER WIRING AND LIGHT DESCRIPTIONS. - DISCONNECT WHITE AND ORANGE PHOTOCELL LEADS FROM FIELD WIRING. CHECK THE WHITE AND ORANGE LEADS FOR CONTINUITY. THERE SHOULD ONLY BE CONTINUITY WHEN THE BEAM IS BLOCKED.

(i) INPUTS ARE SHOWN ON THE TOP OF THE PLC DISPLAY. IF AN INPUT IS SHADED IT IS ACTIVE (RECEIVING A SIGNAL FROM THE ACTIVATION DEVICE).

(ii) OUTPUTS ARE SHOWN ON THE BOTTOM OF THE PLC DISPLAY. IF AN OUTPUT IS SHADED IT IS ACTIVE.

INSTALLATION AND COMMISSIONING CHECKLIST
DIMENSIONS IN PARENTHESIS ARE IN MILLIMETERS

SM-0161
 Rev. B

SERIAL NUMBER: _____

INSTALLATION ITEMS	DONE
GUIDE SPACING (SEE MANUAL COVER PAGE FOR DIMENSION)	
GUIDES ARE PLUM WITH ¼" (6) FROM TOP TO BOTTOM	
DRIVE BARREL IS LEVEL WITHIN ¼" (6)	
SPRING PRECHARGE. ONLY IF DOOR IS EQUIPPED WITH COUNTER BALANCE SPRINGS (SEE DOOR INFORMATION STICKER ON SPRING ENDPLATE, OPERATOR OR CONTROL PANEL FOR SPRING PRECHARGE INFO)	
ALL FASTENERS ARE INSTALLED AND TIGHTENED	
CHAINS ARE ALIGNED PROPERLY (DOES NOT APPLY TO DIRECT DRIVE DOORS)	

NAME: _____

DATE: _____

SIGNATURE: _____

NOTES

COMMISSIONING ITEMS - PROCEED IN THE ORDER NOTED BELOW LOWER THE DOOR WITH THE HAND CHAIN UNTIL IT IS ¾ OPEN	PASS	FAIL
EMERGENCY CHAIN HOIST RAISES AND LOWERS THE DOOR		
EMERGENCY CHAIN HOIST INTERLOCK SWITCH PREVENTS DOOR FROM OPERATING ELECTRICALLY		
CLOSE PUSH BUTTON(S) CLOSES THE DOOR		
DOOR SLOWS DOWN PRIOR TO REACHING FULL CLOSED (VFD CONTROL PANELS ONLY)		
DOOR SEALS AGAINST THE FLOOR ON THE CLOSE LIMIT WITH THE CURTAIN TIGHT IN THE OPENING		
OPEN PUSH BUTTON(S) OPENS THE DOOR		
DOOR SLOWS DOWN PRIOR TO REACHING FULL OPEN (VFD CONTROL PANELS ONLY)		
DOOR STOPS ABOVE THE LINTEL ON THE OPEN LIMIT		
STOP PUSH BUTTON(S) STOPS THE DOOR		
VERIFY THE DOOR IS TRACKING STRAIGHT AS IT OPENS AND CLOSES		
REVERSING EDGE REVERSES THE DOOR TO THE FULL OPEN POSITION		
PHOTOCELL/LIGHT CURTAIN REVERSES THE DOOR TO THE FULL OPEN POSITION		
AUXILLIARY OPEN DEVICES OPEN DOOR (IF EQUIPPED)		
TIMER TO CLOSE CLOSES THE DOOR (IF EQUIPPED)		
TRAFFIC LIGHTS FUNCTIONING (IF EQUIPPED)		

NAME: _____

DATE: _____

SIGNATURE: _____

NOTES

**MAINTENANCE SCHEDULE / SPARE PARTS
DIMENSIONS IN PARENTHESIS ARE IN MILLIMETERS**

SM-0092
Rev. B

IMPORTANT:
DISCONNECT AND LOCK-OUT POWER SUPPLY BEFORE SERVICING MOVING PARTS
COPY THIS SHEET TO RECORD MAINTENANCE HISTORY.

ANNUAL MAINTENANCE SCHEDULE			CHECK LIMIT CHAIN TENSION	CHECK DRIVE CHAIN TENSION	CHECK SPRING CHAIN TENSION	LUBRICATE ALL CHAINS	TEST FUNCTION OF REVERSING EDGE	TEST FUNCTION OF REVERSING PHOTOSWITCH	CHECK OPEN AND CLOSE LIMIT SETTINGS	CHECK FOR LOOSE FASTENERS	CHECK COUNTERBALANCE SPRINGS	LUBRICATE COUNTERBALANCE SPRINGS	CHECK OPERATOR BRAKE RG	CHECK OPERATOR BRAKE HG	INSPECT CURTAIN LOKS	INSPECT WINDBAR STRAPS
DATE	CYCLES	SCHEDULE														
DOOR SERIAL No.: _____																
FOR THE YEAR _____																
WHEN PERFORMING SCHEDULED MAINTENANCE, RECORD DATE AND CURRENT CYCLE COUNT. PERFORM CHECK/TEST/TASKS AS INDICATED BY AN UNSHADED BOX. INITIAL BOX TO INDICATE MAINTENANCE ITEM HAS BEEN PERFORMED.																
		JANUARY														
		FEBRUARY														
		MARCH														
		APRIL														
		MAY														
		JUNE														
		JULY														
		AUGUST														
		SEPTEMBER														
		OCTOBER														
		NOVEMBER														
		DECEMBER														

Note 1 - Proper limit chain tension is about 1/8" (3) slack in each direction for total movement of about 1/4" (6).

Note 2 - Proper drive chain tension is dependent on the door model. See operator installation page in the installation and service manual for proper drive chain tension.

Note 3 - Spring chain tension is maintained by a spring loaded tensioner, inspect for wear and adjustment. Ensure the chain is taut.

Note 4 - Conditions will dictate lubrication requirements, chains must be kept clean and well lubricated with w30 oil.

Note 5 - Standing clear of the curtain's path, compress the reversing edge during the closing cycle. Door should reverse.

Note 6 - Standing clear of the curtain's path, cover the photoswitch beam during the closing cycle. Door should reverse.

Note 7 - Cycle the door to the open and close position. Check for adequate stopping locations.

Note 8 - Check for any loose fasteners, tighten as required. Check alignment of sprockets and verify set screws are tight every 10,000 cycles.

Note 9 - Visually check for broken spring wire.

Note 10 - Apply a spray lubricant to both the inner and outer spring to reduce noise and maintain intended spring life during initial installation and as maintenance schedule dictates. Recommended lubricant is "fluid film" made by eureka.

Note 11 - Inspect and adjust brake if required, replace if necessary. Brake adjustment is dependent on motor model. Refer to operator brake adjustment page in manual.

Note 12 - Visually inspect all curtain loks for damage or if any are missing.

Note 13 - Visually inspect windbar straps for frays and cuts. Replace if necessary. Replace windbar straps every 2 years or 300 000 cycles

Recommended spare parts

There are no parts to replace on the door system during regular maintenance checks. As the maintenance schedule approaches 100,000 cycles (or optional 200,000 cycle springs) replacement springs may be ordered to facilitate a scheduled change.

Knock-away bolts & nuts should be kept on hand for the bottom bar assembly in case of impact.

**HDC, HDC-DD, HDP, HDP-DD,
HDT, HDS, HDL23, HDL45,
HDL23-DD, HDL45, HDL45-DD,
HDXL6, HDXL7, HDXL8**

HDE

Description	QTY
Bottom bar arm	1 set
Curtain lok kit	2
Knockaway bolts (1/4-20nc x 3/4" lg hhcs grade 5 plated)	4
Knockaway (nuts1/4-20nc hex nut plated)	4
Brake kit	1

Description	QTY
Bottom bar arm	1 set
Curtain lok kit	2
Knockaway bolts (1/4-20nc x 3/4" lg hhcs grade 5 plated)	4
Knockaway (nuts1/4-20nc hex nut plated)	4
Inertia brake (Only required when equipped)	1

HDXL9

Description	QTY
Bottom bar arm stop (wear pad)	1 set
Curtain lok kit	4

Doors noted above will have a coil cord as standard and are a recommended spare part.

If wireless edge is optioned, transmitter battery (lithium 3v cr15h270) is a recommended spare part and the coil cord is not required.

HDM, HDD

Description	QTY
Bottom bar arm	1 set
Curtain lok kit	2
Knockaway bolts (1/4-20nc x 3/4" lg hhcs grade 5 plated)	4
Knockaway (nuts1/4-20nc hex nut plated)	4

HSR

Description	QTY
Bottom bar arm	1 set
Wireless edge transmitter battery (Lithium 3v cr15h270)	1

HDFX

Description	QTY
Bottom bar arm	1 set
Curtain lok kit	2
Knockaway bolts (1/4-20nc x 3/4" lg hhcs grade 5 plated)	4
Knockaway (nuts1/4-20nc hex nut plated)	4
Wireless edge transmitter battery (Lithium 3v cr15h270)	1

CHILLFAST

Description	QTY
Coil cord	1
Bottom bar arm	1 set

HDF

Description	QTY
Bottom bar arm	1 set
Wireless edge transmitter battery (Lithium 3v cr15h270)	1

HG OPERATOR BRAKE ADJUSTMENT
DIMENSIONS IN PARENTHESIS ARE IN MILLIMETERS

SM-0074

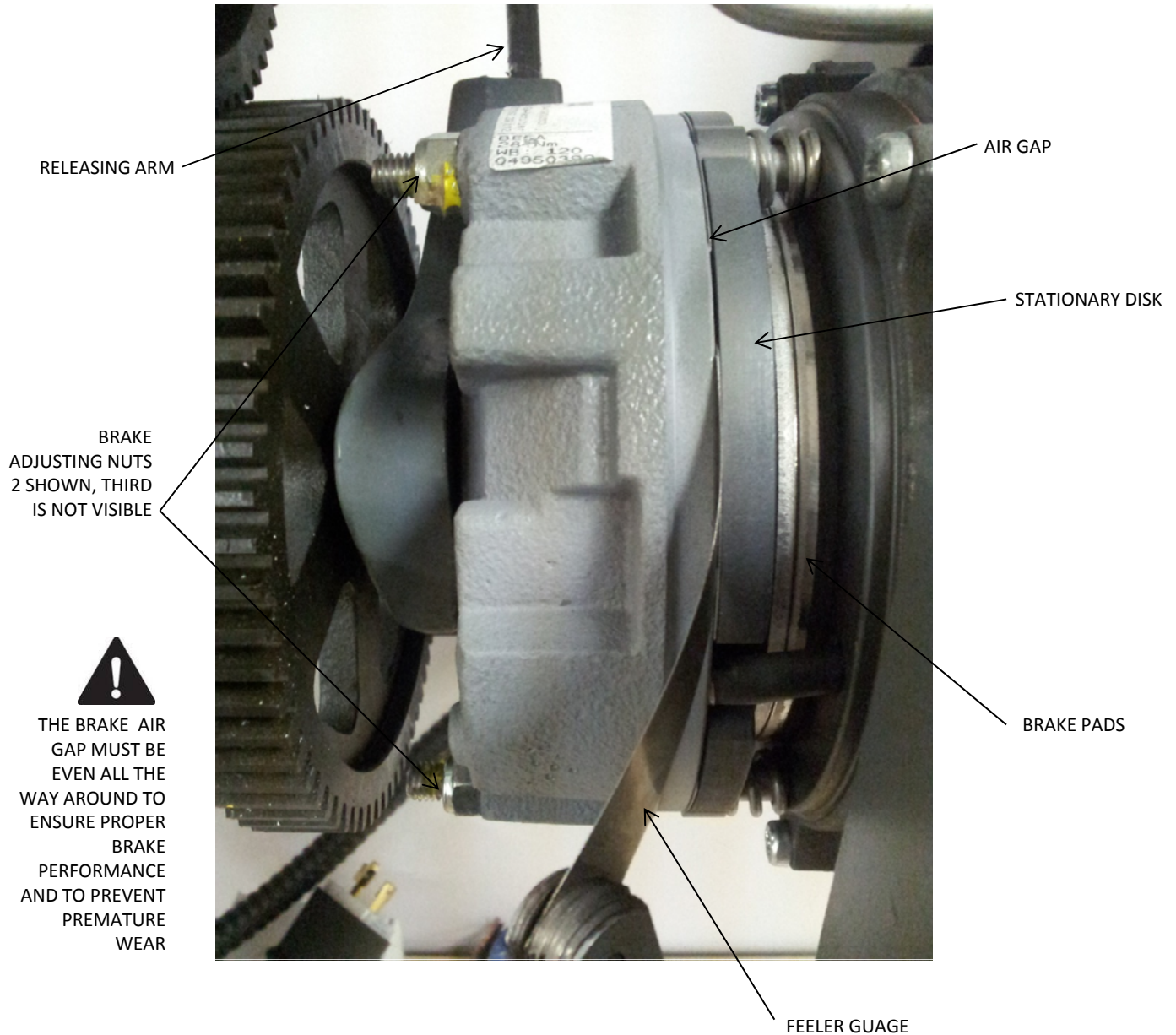

⊗ ENSURE THE PRIMARY POWER TO THE CONTROL PANEL IS LOCKED OUT PRIOR TO COMMENCING WORK SO THAT THE DOOR CAN'T START UP UNEXPECTEDLY.

Periodically clean the motors ventilation intake and its cooling fans proper cooling. The bearings should be checked, cleaned and re-greased every five thousand (5 000) hours of operation. The bearings should be greased to 1/3 of the available space between the outrace and rolling members to avoid overheating. If the brake disc thickness becomes 0.350" (9) or less, replace it (new brake disc thickness is 0.465" (11.8)). Otherwise, reset the air gap and floating clearance as required.

On a properly set brake, the air gap must be within 0.010 – 0.014" (0.25 – 0.36) . Prolonged use of the brake will wear the brake lining which will increase the air gap. As the air gap approaches its maximum value, reset the brake as follows.

(i) Remove the Guard

(ii) Insert a feeler gauge between the brake coil body and the pressure plate. Tighten the brake adjusting nuts until 0.25mm (0.010") air gap is reached equally all around.

(iii) Ensure a floating clearance of 1.5 – 2.0 mm (0.060 – 0.080 inches) in the releasing arm. Releasing arm adjuster nuts are behind the motor gear.

**CURTAIN RESET PROCEDURE
LEFT HAND DOOR WITH RG OPERATOR SHOWN
DIMENSIONS IN PARENTHESIS ARE IN MILLIMETERS**

SM-0079

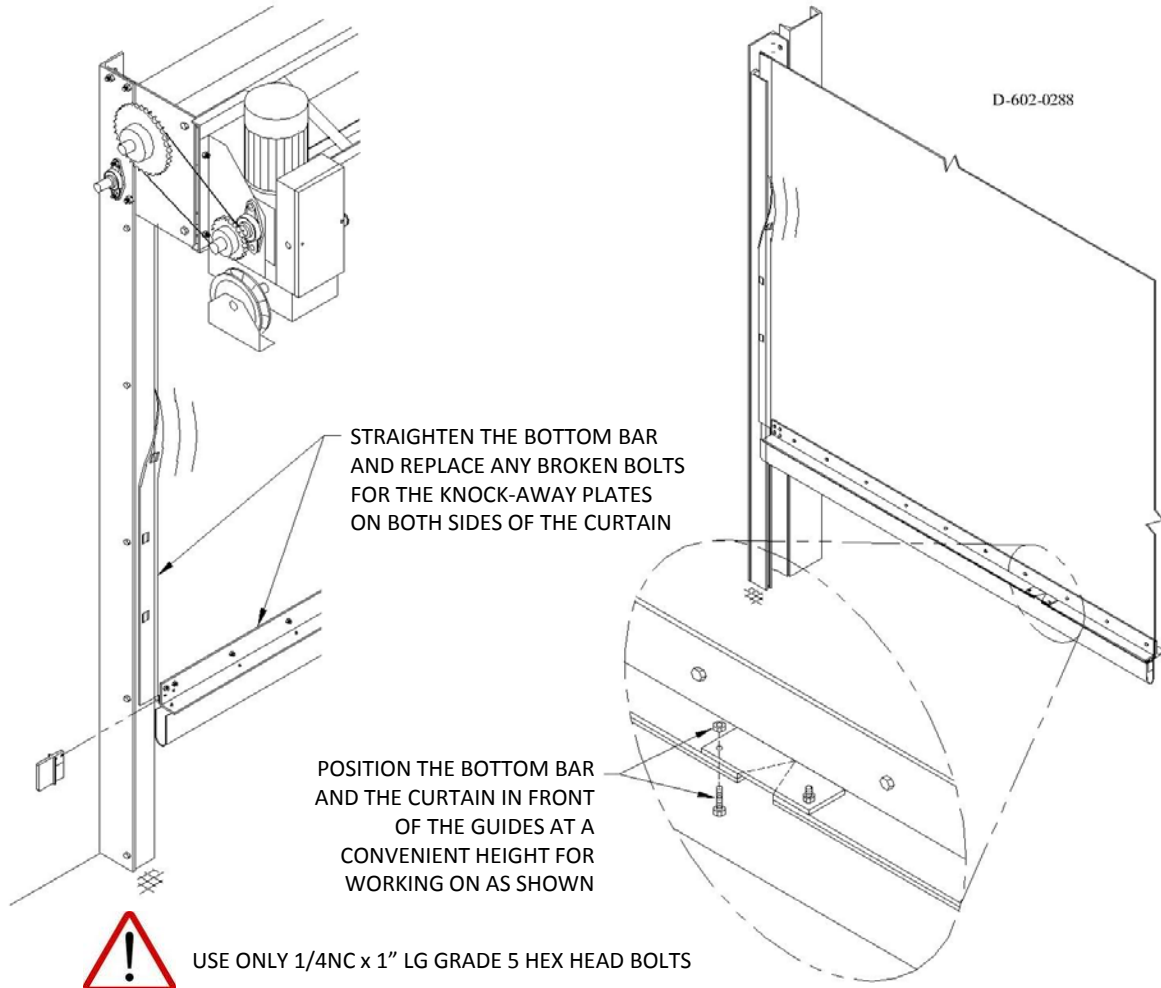

IF THE DOOR WAS ACCIDENTALLY IMPACTED OR HAS BLOWN OUT DUE TO HIGH WIND LOADS, FOLLOW THIS PROCEDURE TO RESET AND RECOMMISSION THE DOOR FOR NORMAL OPERATION:



1. TURN OFF ALL ELECTRICAL POWER TO THE DOOR AND LOCK OUT THE DOOR.

2. POSITION THE BOTTOM BAR AND THE CURTAIN IN FRONT OF THE GUIDES AS SHOWN IN DIAGRAM #1 AND USING THE MANUAL CHAIN HOIST POSITION THE DOOR AT A CONVENIENT HEIGHT FOR WORKING ON.

3. EXAMINE THE BOTTOM BAR ARMS, REVERSING EDGE, COIL CORD AND THE CURTAIN FOR ANY DAMAGE. REPLACE DAMAGED PARTS IF THEY CAN NOT BE REPAIRED.

4. STRAIGHTEN THE BOTTOM BAR AND REPLACE ALL BROKEN BOLTS FOR THE KNOCK-AWAY PLATES WITH 1/4-20NC x 1" LG GRADE 5 HEX HD CAP SCREW AS SHOWN IN DIAGRAM #2. INSERT THE BOLT FROM THE BOTTOM, SO THE NUT IS ON TOP.



5. REMOVE THE BOTTOM BAR ARMS.

6. USING THE MANUAL CHAIN HOIST, RAISE THE BOTTOM BAR ABOVE THE TOP OF THE GUIDES, THIS WILL ALLOW THE BOTTOM BAR ARMS AND THE CURTAIN TO FALL BACK INTO THE GUIDES.

7. MANUALLY LOWER THE DOOR A MINIMUM OF 24 INCHES ENSURING THAT THE CURTAIN IS BEING FED DOWN INTO THE GUIDES PROPERLY.

8. TURN ON THE POWER TO THE DOOR, LOWER THE CURTAIN AND REINSTALL THE BOTTOM BAR ARMS.

9. TEST CYCLE THE DOOR APPROXIMATELY TEN TIMES TO VERIFY THE LIMIT SETTINGS. BE PREPARE TO STOP THE DOOR IF THE DOOR DOES NOT OPERATE PROPERLY.

10. REMOVE THE LOCK OUT TAG AND COMMISSION THE DOOR FOR NORMAL OPERATION.

PRIMARY PARTS LIST
LEFT HAND DOOR SHOWN

SM-0101
Rev. A

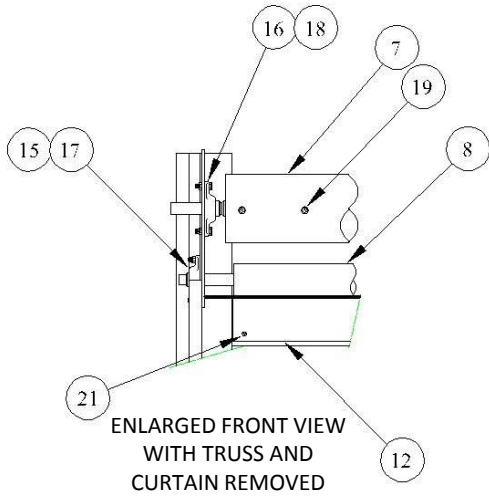

ENLARGED VIEW OF ITEM 27
CURTAIN LOKS ARE INSTALLED ON EACH
VERTICAL EDGE OF THE CURTAIN

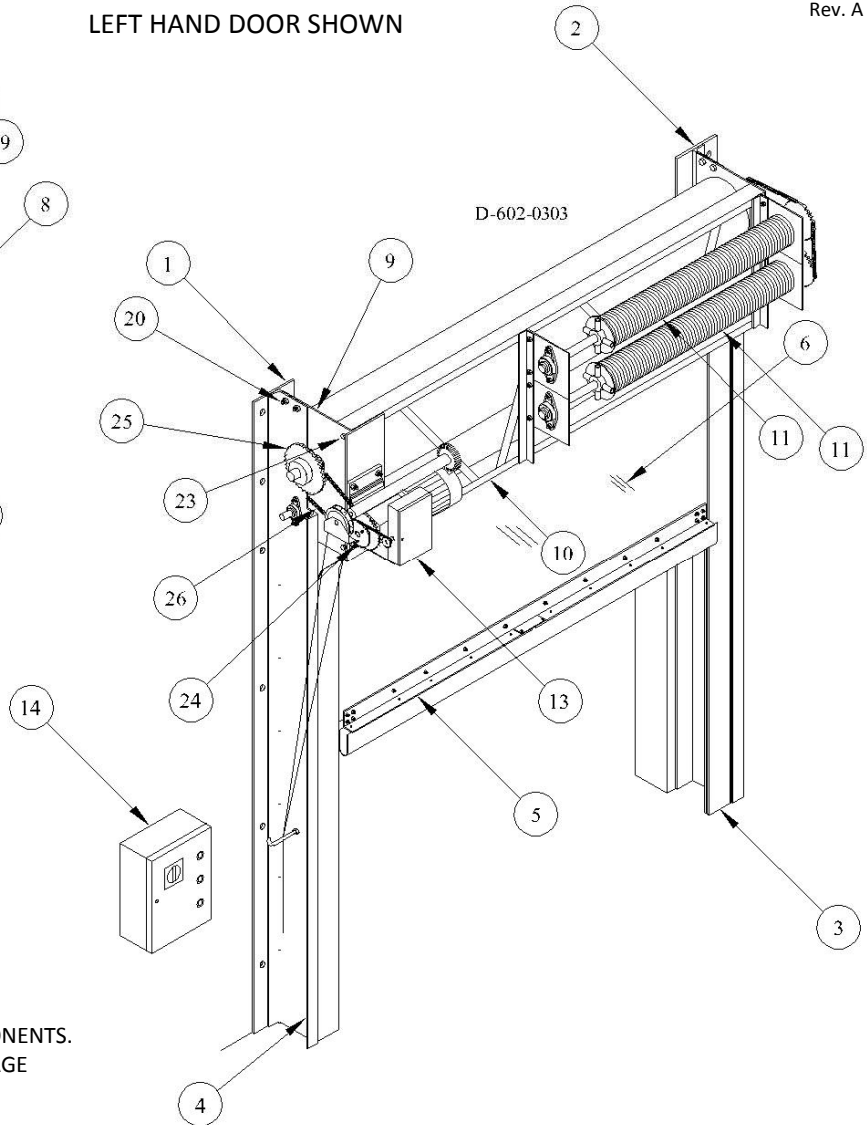
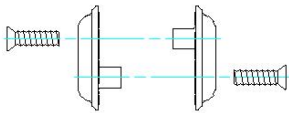

* SEE ADDITIONAL PARTS LIST FOR SUB COMPONENTS.
*** SEE OPERATOR MOUNTING HARDWARE PAGE

ITEM	QTY	DESCRIPTION	ITEM	QTY	DESCRIPTION
1	1	DOOR MOUNTING CHANNEL, LEFT HAND	15	2	IDLER BARREL BEARING, 1 1/2" I.D.
2	1	DOOR MOUNTING CHANNEL, RIGHT HAND	16	2	DRIVE BARREL BEARING, 2 1/2" I.D.
3	2	ALUMINUM GUIDE, FABRICATED	17	2	BEARING MOUNTING HARDWARE KIT, 2 BOLT
4	VARIES	GUIDE MOUNTING BOLT (10 BOLT KIT)	18	2	BEARING MOUNTING HARDWARE KIT, 4 BOLT
5	1	* BOTTOM BAR ASSEMBLY	19	VARIES	CURTAIN BOLT & WASHER (10 PAIR KIT)
6	1	CURTAIN ASSEMBLY	20	1	DOOR MOUNTING HARDWARE KIT
7	1	DRIVE BARREL ASSEMBLY	21	VARIES	LINTEL HARDWARE KIT (10 SCREW KIT)
8	1	IDLER BARREL ASSEMBLY	22	1	*** OPERATOR MOUNTING HARDWARE KIT
9	2	ENDPLATE	23	1	TRUSS MOUNTING HARDWARE KIT
10	1	TRUSS ASSEMBLY	24	1	OPERTOR DRIVE SPROCKET
11	VARIES	* SPRING SHAFT ASSEMBLY	25	1	DOOR DRIVE SPROCKET
12	1	* LINTEL ASSEMBLY	26	1	OPERTOR DRIVE CHAIN (10FT)
13	1	* ELECTRIC OPERATOR	27	VARIES	HD CURTAIN LOK, ASS'Y KIT (5 PAIRS)
14	1	* ELECTRIC CONTROL PANEL	28	-	-

BOTTOM BAR ASSEMBLY PARTS LIST

SM-0106

LEFT HAND BOTTOM BARS SHOWN

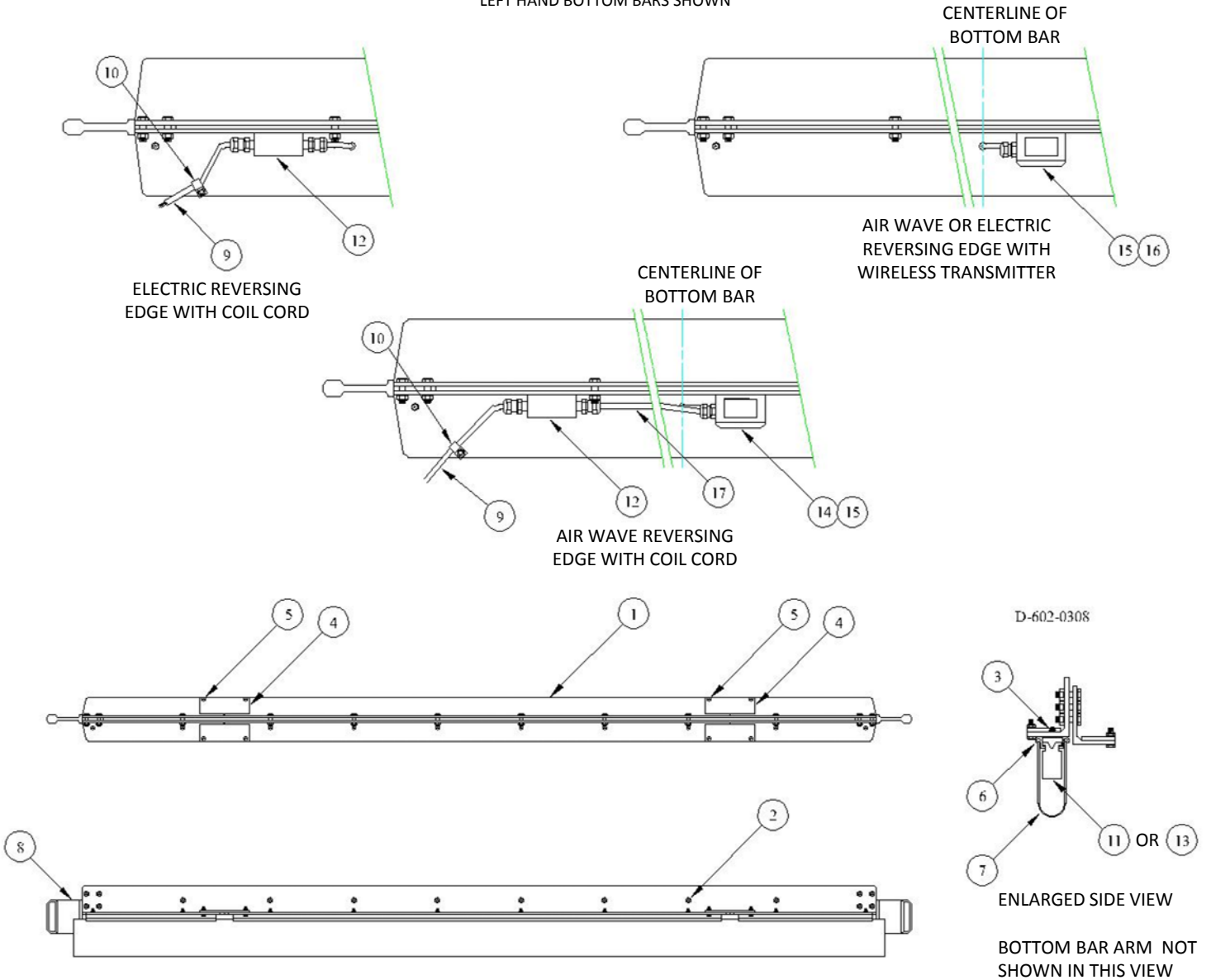

- * PARTS APPLY TO ELECTRIC REVERSING EDGE ONLY
- ** PARTS APPLY TO AIR WAVE REVERSING EDGE ONLY
- *** PARTS APPLY TO WIRELESS REVERSING EDGE ONLY

ITEM	QTY	DESCRIPTION	ITEM	QTY	DESCRIPTION
1	1	BOTTOM BAR STRUCTURE	11	1	* AIR WAVE REVERSING EDGE (PNEUMATIC)
2	VARIABLES	B-BAR MOUNTING BOLT & NUT (10 PAIR KIT)	12	1	** STONCO BOX JUNIOR KIT
3	VARIABLES	RETAINER MOUNTING BOLT & NUT (10 PAIR KIT)	13	1	** ELECTRIC REVERSING EDGE
4	2	KNOCK-AWAY PLATE	14	1	* AIR WAVE SWITCH
5	1	KNOCK-AWAY BOLT & NUT (4 PAIR KIT)	15	2	SWITCH/TRANSMITTER MOUNTING SCREWS
6	2	ALUMINUM RETAINER	16	1	*** WIRELESS TRANSMITTER
7	1	RUBBER LOOP EXTRUSION	17	1	** REVERSING EDGE CABLE
8	2	BOTTOM BAR ARM	18	-	-
9	1	COIL CORD	19	-	-
10	1	WIRE CLIP	20	-	-

SPRING SHAFT ASSEMBLY PARTS LIST

SM-0108

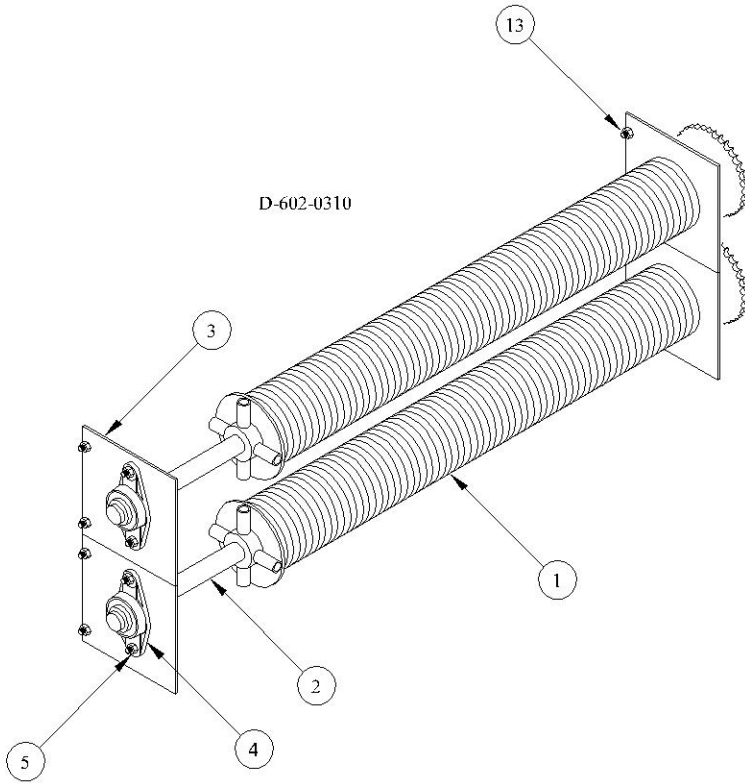

D-602-0310

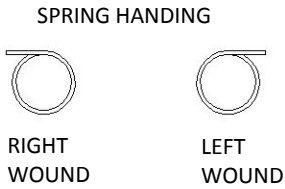
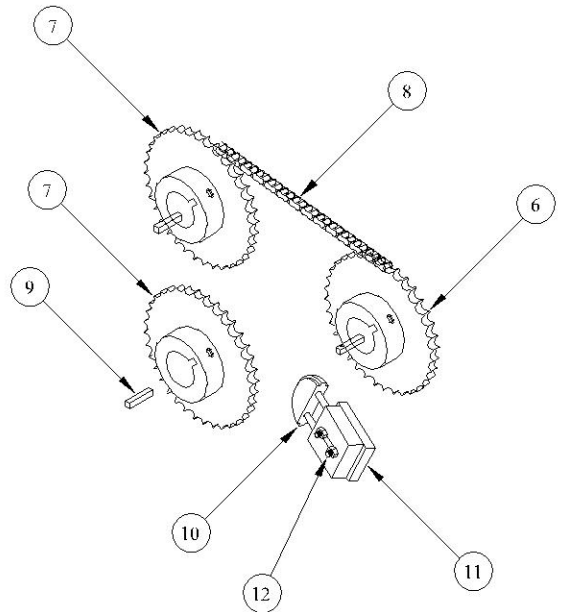

SPRING LOCATION FOR A RIGHT HAND DOOR

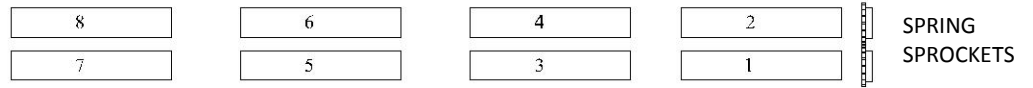
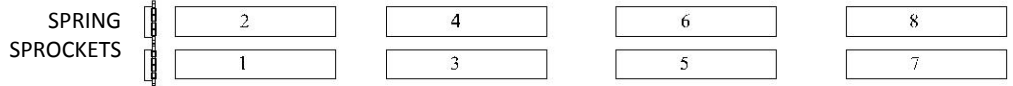

* IF ORDERING A SINGLE SPRING ASSEMBLY FOR A MULTI SPRING CONFIGURATION, SPECIFY EITHER THE SPRING HANDING OR THE SPRING LOCATION.

SPRING LOCATION FOR A LEFT HAND DOOR

ITEM	QTY	DESCRIPTION	ITEM	QTY	DESCRIPTION
1	VARIES	* SPRING ASSEMBLY	8	VARIES	SPRING CHAIN (10FT)
2	VARIES	SPRING SHAFT	9	VARIES	KEYSTOCK
3	VARIES	SPRING ANCHOR PLATE	10	VARIES	CHAIN TENSIONER
4	VARIES	SPRING SHAFT BEARING, 1 1/2" I.D.	11	VARIES	CHAIN TENSIONER BASE
5	VARIES	HEX NUT	12	VARIES	CHAIN TENSIONER MOUNTING BOLT KIT
6	VARIES	SPRING DOOR SPROCKET	13	VARIES	ANCHOR PLATE FASTENER KIT (MOUNTS 1 PLATE)
7	VARIES	SPRING SHAFT SPROCKET	14	-	-

LINTEL SEAL ASSEMBLY PARTS LIST

SM-0109

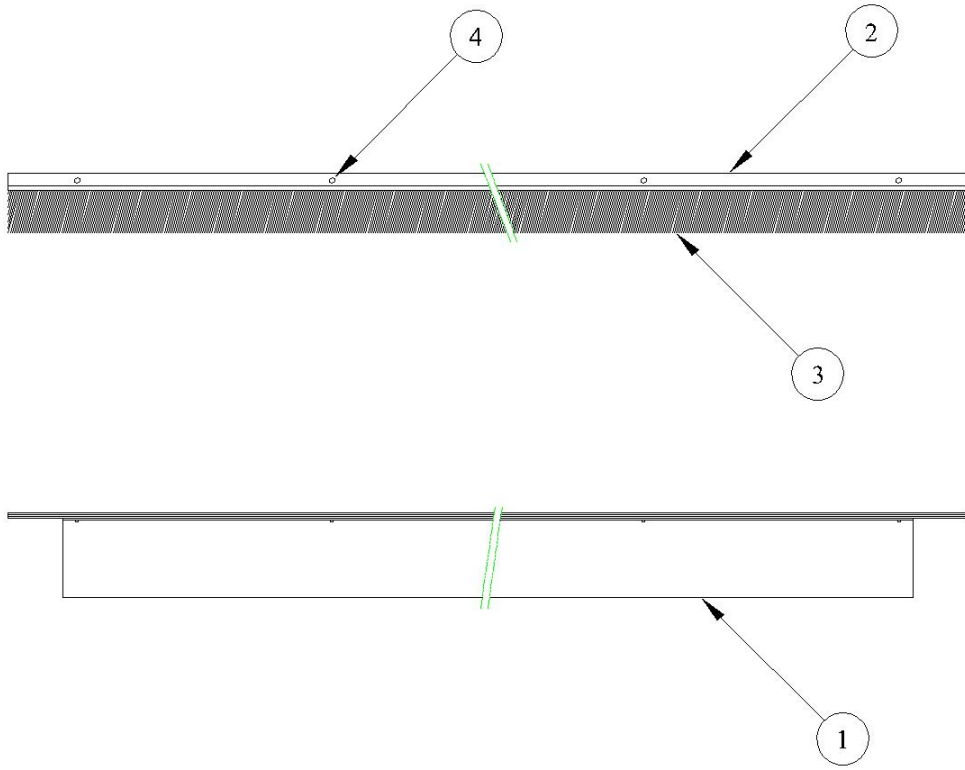

D-602-0311

ITEM	QTY	DESCRIPTION	ITEM	QTY	DESCRIPTION
1	1	BRUSH RETAINER HOLDER	4	VARIES	RIVETS
2	1	ALUMINUM RETAINER	5	-	-
3	1	BRUSH	6	-	-

OPERATOR MOUNTING HARDWARE PARTS LIST

SM-0110

“RG” DRIVE SYSTEM

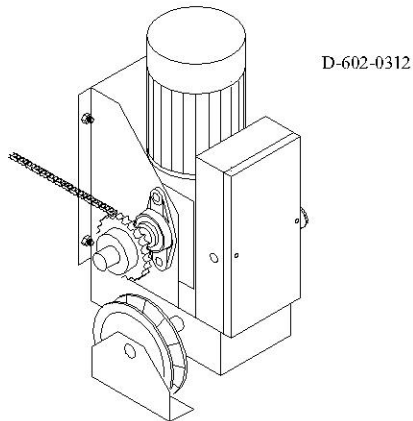

ITEM	QTY	DESCRIPTION	ITEM	QTY	DESCRIPTION
1	1	MASTERLINK	5	1	KEYSTOCK FOR DOOR DRIVE SPROCKET
2	1	HALKF LINK	6	1	“J” BOLT AND NUT KIT
3	1	“J” CLIP	7	1	RG OPERATOR MOUNTING HARDWARE
4	1	KEYSTOCK FOR OPERATOR DRIVE SPROCKET	8	-	

“HG” DRIVE SYSTEM

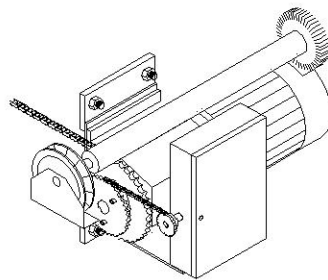

ITEM	QTY	DESCRIPTION	ITEM	QTY	DESCRIPTION
1	1	MASTERLINK	5	1	KEYSTOCK FOR DOOR DRIVE SPROCKET
2	1	HALF LINK	6	1	“J” BOLT AND NUT KIT
3	1	“J” CLIP	7	1	HG OPERATOR MOUNTING HARDWARE
4	1	KEYSTOCK FOR OPERTOR DRIVE SPROCKET	8	-	